

January 2013

Effect of Solids Retention Time on the Denitrification Potential of Anaerobically Digested Swine Waste

Maureen Njoki Kinyua

University of South Florida, mkinyua@mail.usf.edu

Follow this and additional works at: <http://scholarcommons.usf.edu/etd>

 Part of the [Environmental Engineering Commons](#), and the [Oil, Gas, and Energy Commons](#)

Scholar Commons Citation

Kinyua, Maureen Njoki, "Effect of Solids Retention Time on the Denitrification Potential of Anaerobically Digested Swine Waste" (2013). *Graduate Theses and Dissertations*.
<http://scholarcommons.usf.edu/etd/4520>

This Thesis is brought to you for free and open access by the Graduate School at Scholar Commons. It has been accepted for inclusion in Graduate Theses and Dissertations by an authorized administrator of Scholar Commons. For more information, please contact scholarcommons@usf.edu.

Effect of Solids Retention Time on the Denitrification Potential of Anaerobically
Digested Swine Waste

by

Maureen Njoki Kinyua

A thesis submitted in partial fulfillment
of the requirements for the degree of
Master of Science in Environmental Engineering
Department of Civil and Environmental Engineering
College of Engineering
University of South Florida

Major Professor: Sarina J. Ergas, Ph.D.
Jeffrey Cunningham, Ph.D.
Ann C. Wilkie, Ph.D.

Date of Approval:
March 22, 2013

Keywords: Methane, Biodegradable, Anaerobic Digestion, Ammonia, SRT

Copyright © 2013, Maureen Njoki Kinyua

ACKNOWLEDGMENTS

There are many people who assisted me throughout my journey of conducting this research and writing my thesis. I would like to first thank Professor Sarina Ergas, for being extremely supportive, helpful and insightful throughout the process by providing guidelines and answers to my questions. Professor Jeffrey Cunningham for providing constructive feedback and for providing an environment that encouraged me to learn. Professor Ann Wilkie for providing inoculum to start up the reactors and for assisting me in improving my analytical methods. Farmer Ricky Lyons and his family for providing me with the swine waste that was used to run the experiments. I am thankful to Oscar Peña for assisting me in the day to day operations and analysis of the reactors. Thank you Veronica Aponte, Alex Lin, Trina Halfide and Thomas Lynn. I am grateful to my siblings Caroline Kinyua, Robert Kinyua and Diana Kinyua and the family dog, Bubbles for their constant love, support and encouragement. Additionally, this research was supported by research grant No. IS-4360-10 from the United States-Israel Binational Agricultural Research and Development Fund (BARD). Any opinions, findings, conclusions, or recommendations expressed in this thesis are those of the author and do not necessarily reflect the views of BARD.

TABLE OF CONTENTS

LIST OF TABLES	iv
LIST OF FIGURES	vi
ABSTRACT	ix
CHAPTER 1: INTRODUCTION	1
CHAPTER 2: LITERATURE REVIEW	7
2.1 Anaerobic Digestion	7
2.1.1 Benefits of Anaerobic Digestion	7
2.1.1.1 Energy Production and Requirements	7
2.1.1.2 Biomass Production and Nutrient Requirements	8
2.1.1.3 Biogas Production and Methane Mitigation	9
2.1.1.4 Odor Reduction	9
2.1.1.5 Pathogen Reduction	10
2.1.2 Residual Nutrients	10
2.2 Microbial of Anaerobic Digestion	11
2.3 Microbial Relationships	13
2.4 Stoichiometry of Anaerobic Digestion	14
2.5 Anaerobic Digestion of Swine Waste	16
2.5.1 Operating Parameters	16
2.5.1.1 Temperature	19
2.5.1.2 Organic Loading Rate	20
2.5.1.3 Retention Time	21
2.5.1.4 Volatile Solids Reduction and Methane Yield	22
2.5.1.5 pH and Alkalinity	23
2.5.1.6 Volatile Fatty Acids	24
2.5.1.7 Inhibition	25
2.5.1.7.1 Ammonia	25
2.5.1.7.2 Sulfide	27
2.5.2 Anaerobic Reactors and Technologies	28
2.5.2.1 Developed World Processes	29
2.5.2.1.1 Continuously Stirred Tank Reactor	29
2.5.2.1.2 Anaerobic Sequencing Batch Reactor	30
2.5.2.1.3 Upflow Anaerobic Sludge Blanket Reactor	30
2.5.2.2 Developing World Processes	31
2.5.2.2.1 Fixed Dome Digester	32
2.5.2.2.2 Floating Drum Digester	32
2.5.2.2.3 Polyethylene Tubular Digesters	33

2.6 Organic Carbon in Wastewater	35
2.6.1 Influent COD	35
2.6.2 Effluent COD	36
2.6.3 Assessment of COD Fractions	38
2.6.3.1 Readily Biodegradable COD (S_S)	38
2.6.3.2 Slowly Biodegradable COD (X_S)	42
2.6.3.3 Inert COD Fractions and Microbial Products	42
2.6.4 Denitrification Potential	43
CHAPTER 3: MATERIALS AND METHODS	46
3.1 Farmer Lyons and His Operation	46
3.2 Reactor Design and Operation	46
3.2.1 Phase I: Start Up	47
3.2.2 Phase II: SRT Study	47
3.3 Analysis Methods	48
3.3.1 Respirometry	49
3.3.2 Nitrate Removal	50
CHAPTER 4: DATA ANALYSIS	51
4.1 Mass Balances	51
4.1.1 COD Mass Balance Calculations	51
4.1.2 Nitrogen Mass Balance Calculations	56
4.1.3 Phosphorus Mass Balance Calculations	60
4.2 Statistical Significance	63
4.3 Respirometry Analysis	63
CHAPTER 5: RESULTS	65
5.1 Phase I: Start Up	65
5.2 Phase II: SRT Study	67
5.2.1 Overall Performance and Summary	67
5.2.2 Mass Balance Results	68
5.2.2.1 COD Mass Balance	72
5.2.2.2 Nitrogen Mass Balance	73
5.2.2.3 Phosphorus Mass Balance	73
5.2.3 Centrate COD Bioavailability Results	74
5.2.4 Denitrification Test	76
CHAPTER 6: DISCUSSION	78
6.1 Volatile Solids Removal and Methane Yield as a Function of SRT	78
6.2 TAN and FA Concentrations	80
6.3 Mass Balances	82
6.3.1 COD Mass Balance	82
6.3.2 Nitrogen Mass Balance	83
6.3.3 Phosphorus Mass Balance	83
6.4 COD and Denitrification Potential	84
6.4.1 Evaluation of Biodegradable COD Fractions in the Centrate	84
6.4.2 Evaluation of Soluble Microbial Products in the Centrate	87
6.4.3 Effect of Freezing and Thawing Swine Waste	87

6.5 Nitrate Removal by Centrate	89
CHAPTER 7: CONCLUSIONS AND RECOMMENDATIONS	90
REFERENCES	92
APPENDICES	102
Appendix A Analytical Methods	103
A.1 pH and Alkalinity	103
A.2 Biogas Volumes and Methane Content	104
A.3 Total Phosphorus	105
A.4 Total Nitrogen	106
A.5 TAN	107
A.5.1 Reagents	107
A.5.2 Methods	108
A.6 COD	109
A.7 VFA	110
A.7.1 Reagents	111
A.7.2 Methods	111
Appendix B Mass Balances	114
B.1 COD Mass Balance	114
B.2 Nitrogen Mass Balance	117
B.3 Phosphorus Mass Balance	117
Appendix C Phase I Graphs	118
Appendix D List of Acronyms	123
Appendix E List of Equation Nomenclature	124

LIST OF TABLES

Table 1.1:	Summary of pollutants found in raw swine waste, typical concentrations found in literature and environmental impacts	3
Table 2.1:	Benefits of Anaerobic Digestion	8
Table 2.2:	Summary of operating parameters and performance of three commonly used AD technologies used to treat swine waste	17
Table 2.3:	Summary of operating parameters for anaerobic digestion of livestock waste	18
Table 2.4:	Summary of AD operation modes	29
Table 3.1:	Summary of study operation	47
Table 4.1:	Kinetic parameters for AD of swine waste used in steady state Monod hydrolysis kinetics COD mass balance	52
Table 4.2:	Kinetic and biological parameters inputted into Young's general kinetic model software to calculate calculated OU and OUR	64
Table 5.1:	Phase I average performance data results for swine waste from three 1.5 L reactors operated at an OLR of 1.88 kg VS/m ³ -d and SRT of 28 days for 16 weeks	66
Table 5.2:	Phase I average summary results for swine waste influent and effluent three 1.5 L reactors operated at an OLR of 1.88 kg VS/m ³ -d and SRT of 28 days for 16 weeks	66
Table 5.3:	Phase II average performance data for three 1.5L reactors' swine waste operated at an OLR of 1.88 kg VS/m ³ -d and varying SRT for 12 weeks	69
Table 5.4:	Phase II average summary data for three 1.5 L reactors' swine waste operated at an OLR of 1.88 kg VS/m ³ -d and varying SRT for 12 weeks	69
Table 5.5:	Calculated COD balance for the three reactors based Monod hydrolysis kinetics	72

Table 5.6:	Calculated influent and effluent N concentrations and N mass balance	73
Table 5.7:	Calculated influent P and effluent P concentrations and P mass balance	74
Table 5.8:	COD fraction, concentrations, centrate ratios and statistical difference between the three reactors	74
Table 6.1:	Phase II week 2 reactors' performance in terms of pH, CH ₄ yield, TAN and FA concentrations	80
Table A.1:	Summary of analytical methods	103
Table B.1:	First order kinetic calculations	115
Table B.2:	Linearization methods and calculated kinetic constants for Monod kinetics	116

LIST OF FIGURES

Figure 1.1:	Schematic for proposed treatment of swine waste	4
Figure 2.1:	Anaerobic digestion process	15
Figure 2.2:	Agricultural AD components	29
Figure 2.3:	Anaerobic processes and reactors	34
Figure 2.4:	Small scale anaerobic digesters	34
Figure 2.5:	Total influent COD fractionation	37
Figure 2.6:	Total effluent COD fractionation	38
Figure 2.7:	Total influent particulate COD fractionation	38
Figure 2.8:	OUR profile for aerobic batch test	40
Figure 2.9:	NUR profile for anoxic batch test	41
Figure 3.1:	Respirometer test set-up	50
Figure 4.1:	COD flow through steady state AD process model	53
Figure 4.2:	Conceptual model for COD mass balance	54
Figure 4.3:	Conceptual model for nitrogen mass balance	59
Figure 4.4:	Nitrogen flow through steady state AD process model	59
Figure 4.5:	Conceptual model for phosphorus mass balance	62
Figure 4.6:	Phosphorus flow through AD process	62
Figure 5.1:	Comparison of CH ₄ yield (A), biogas production (B) and % VS removal (C) during Phase II for three reactors operating at varying SRT	70
Figure 5.2:	Comparison of TAN concentrations (A), FA concentrations (B) and pH (C) during Phase II for three reactors operating at varying SRT	71
Figure 5.3:	Comparison between % measured and % calculated COD removal	73

Figure 5.4:	Measured and model OUR and OU respirometric curves for the three reactors during respirometry tests using the centrate (soluble COD) portion of swine AD effluent and MLVSS from a WWTP A: 14 day, B: 21 day and C: 28 day SRT	75
Figure 5.5:	Average effluent soluble COD fractions in the three SRT reactors during Phase II	76
Figure 5.6:	Results from a denitrification microcosm to measured NO_3^- removal with each reactor's centrate as carbon source (Note: No error bars are shown due to very low standard deviation)	77
Figure 6.1:	Standardized hydrolysis rate calculated by dividing hydrolysis rate by total influent COD concentration	79
Figure 6.2:	Biodegradable effluent COD fractions from the three reactors	86
Figure A.1:	CH_4 content analysis set-up	105
Figure A.2:	CH_4 calibration curve using 3.0N NaOH	105
Figure A.3:	TP calibration curve using stock solutions prepared using adenosine triphosphate and a spectrophotometer wavelength of 880 nm	106
Figure A.4:	TN calibration curve using stock solutions prepared using nicotinic acid <i>p</i> -toluenesulfonate and a spectrophotometer wavelength of 543 nm	107
Figure A.5:	TAN calibration curve using stock solutions prepared using ammonium chloride and a spectrophotometer wavelength of 685 nm	109
Figure A.6:	COD calibration curve using stock solutions prepared using potassium hydrogen phthalate and a spectrophotometer wavelength of 600 nm	110
Figure A.7:	VFA calibration curve using stock solutions prepared using acetic acid and a spectrophotometer wavelength of 500 nm	113
Figure B.1:	Lineweaver-Burke linearization and regression method for the three reactors	115
Figure B.2:	Eadie-Hofstee linearization and regression method for the three reactors	116
Figure C.1:	Total Solids influent and effluent concentrations for 16 weeks of Phase I	118
Figure C.2:	Volatile Solids influent and effluent concentrations for 16 weeks of Phase I	118

Figure C.3:	Alkalinity influent and effluent concentrations for 16 weeks of Phase I	119
Figure C.4:	TAN influent and effluent concentrations for 16 weeks of Phase I	119
Figure C.5:	Soluble Nitrogen influent and effluent concentrations for 16 weeks of Phase I	120
Figure C.6:	Total Nitrogen influent and effluent concentrations for 16 weeks of Phase I	120
Figure C.7:	Soluble Phosphorus influent and effluent concentrations for 16 weeks of Phase I	121
Figure C.8:	Soluble COD influent and effluent concentrations for 16 weeks of Phase I	121
Figure C.9:	Total COD influent and effluent concentrations for 16 weeks of Phase I	122
Figure C.10:	Total COD influent and effluent concentrations for 16 weeks of Phase I	122

ABSTRACT

Three continuously stirred tank reactors (CSTR) were operated in semi continuous mode treating swine waste using anaerobic digestion. The reactors were used to test the effect of solid retention time (SRT) on CH₄ yield, total ammonia nitrogen (TAN) concentrations, % volatile solids (VS), chemical oxygen demand (COD) and volatile fatty acids (VFA) removal, readily biodegradable COD concentration and the denitrification potential for the effluent in a biological nutrient removal (BNR) system. During Phase I of the study, the three reactors were operated at the same 28 day SRT for 16 weeks. SRTs were then changed during the 12 week Phase II period. The SRTs studied were 14, 21 and 28 days, with the same organic loading rate (OLR) of 1.88 ± 0.2 kg VS/ m³-day. The reactor with the lowest SRT (14 days) had the highest VS and VFA removal at 73.6 and 67.6% and lowest TAN concentration at 0.78 g NH₄⁺-N/L, followed by the 21 day and 28 day reactors. This was likely due to the fast microbial growth rates and substrate utilization rates in this reactor compared with the other two. The 14 day reactor had the highest CH₄ yield at 0.33 m³CH₄/kg VS added and readily biodegradable COD concentration at 0.93 COD/L. The variations in CH₄ yield and readily biodegradable COD concentrations between the three reactors were not statistically significant. Denitrification potential for the reactors was 1.20, 0.73 and 0.56 g COD/g N for 14, 21 and 28 day reactors, respectively, and the differences were statistically significant. None of the reactors achieved a denitrification potential of 5 g COD/g N, the amount required to use effluent of anaerobically digested swine waste as an internal

carbon source in a BNR. This was attributed to operating conditions such as freezing and thawing of the raw swine waste that maximized CH₄ yield and lowered the readily biodegradable COD concentration. In addition the 14 day reactor had low TAN concentrations thus increasing the denitrification potential of the centrate from that reactor.

CHAPTER 1: INTRODUCTION

Increasing demand for meat worldwide has led to the construction of large concentrated animal feeding operations (CAFO) for livestock. Pigs make up 40% of the world's meat demand, and swine waste presents a number of problems for CAFOs (Choi, 2007). Untreated swine waste contains organic matter, nutrients of concern such as nitrogen (N) and phosphorus (P), suspended solids (SS), pathogens, odorous volatile compounds, trace elements, and other chemicals of concern. A summary of these pollutants, their typical concentrations in swine waste, and their impact on the environment is shown in Table 1.1.

Land application is a common method for disposing of CAFO waste in the United States (US) and the European Union (EU) (Bernet & Beline, 2009). However, waste produced in CAFOs often surpasses the amount that can be used directly on the land without causing a strain to the environment (Chynoweth et al., 1999). Continuous land application of CAFO waste causes water pollution due to runoff, air pollution from the volatilization of the compounds in the waste, and soil and groundwater pollution from infiltration. Runoff of CAFO waste into surface water can deplete dissolved oxygen (DO), and DO levels below 4 mg O₂/L are detrimental to aquatic life (Mihelcic et al., 2011). According to the United States Environmental Protection Agency (USEPA) 2000 national water quality inventory, pollutants summarized in Table 1.1 are the main causes for decreased water quality for water bodies in the US. In the US, more than 50% of the rivers and bays along the coasts have been affected by algal blooms due to excess

nutrients (Pew Oceans Commission, 2003). It is therefore critical for human health and the environment to improve water quality, which necessitates reduction of CAFO waste disposal.

A commonly used treatment process for swine waste is anaerobic lagoons (AL). These are deep layered openings in the ground that are maintained under anaerobic conditions for the removal of organic matter. ALs can either be covered or uncovered. The top layer of an open AL can be aerobic. ALs are inexpensive, but have high land requirements; up to 20 times more space compared to anaerobic digesters (AD) (Moser, ND). ALs also differ from AD in that they are unheated, unmixed and open to the atmosphere (Bowman et al., 2002; Rittmann and McCarty, 2001). ALs release low quality effluent, produce odors, and release greenhouse gases (GHG) to the atmosphere (Chynoweth et al., 1999). An uncovered swine lagoon in North Carolina produced 0.03-0.1 m³ biogas/m²-day and 60 to 70% of the biogas was methane (Westerman et al., 2008).

In an effort to reduce GHG emissions and improve waste management methods, the USEPA requires that CAFOs limit land application of waste and the use of uncovered and unlined lagoons (USEPA, 2008). Therefore, farmers are seeking alternative technologies such as AD. One major advantage of using AD systems is that the biogas produced is captured. Farmers can either utilize the green renewable energy on their farms to heat water or buildings, or to generate electricity, which can be used on site or sold to power companies (Westerman et al., 2008).

Table 1.1: Summary of pollutants found in raw swine waste, typical concentrations found in literature and environmental impacts

	Pollutants	Typical concentrations	Environmental impact	Reference
Organic Matter	COD (g/L)	10-80	<ul style="list-style-type: none"> Carbon based biodegradable compounds degraded by microorganisms in water bodies leads to low DO levels that affect aquatic life Biodiversity in water bodies is lowered from depleting DO 	Astrals et al., 2012; Chynoweth et al., 1999; Im & Gi, 2011; USEPA, 2002
	BOD (g/L)	1-20		
Solids	SS (%)	1-8	<ul style="list-style-type: none"> Increases turbidity in water bodies Decrease in light penetration affects aquatic plants that some aquatic animals depend on Solids encourage the accumulation and transport of nutrients 	USEPA, 2002; Zarkadas & Pilidis, 2011
Nutrients	TN (g/L)	2-6	<ul style="list-style-type: none"> Reduces DO by exerting NOD to water High levels lead to eutrophication in water bodies Aquatic life is negatively affected Fish kills lower biodiversity in water bodies TP Increases cost for drinking water treatment plants and produces odors NH₄⁺ is toxic to aquatic life 	Bernet & Beline, 2009; Choi, 2007; Nuchdang & Phalakornkule, 2012; USEPA, 2002
	TP (g/L)	0.3-1.1		
	NH ₄ ⁺ -N (g/L)	1.2-3.1		
Pathogens	<i>Campylobacter spp.</i> , <i>Salmonella</i> , <i>Listeria monocytogenes</i> , <i>E.coli</i> O157:H7, <i>Cryptosporidium parvum</i> , <i>Giardia lamblia</i> , <i>Ascaris</i>		<ul style="list-style-type: none"> Waterborne diseases that cause illness to humans and animals 	Dold & Holland (2011); USEPA, 2002

Table 1.1 (Continued)

VOC	Volatile Fatty Acids (VFA), phenols, mercaptans, hydrogen sulfide (H ₂ S)	N/A	<ul style="list-style-type: none"> Air pollution leading to respiratory health issues to both the farm workers and the animals Odorous compounds can be a nuisance 	Chynoweth et al., 1999; Wilkie, 2005
Trace elements	Copper, Zinc, Boron, Magnesium, Iron And Lead	N/A	<ul style="list-style-type: none"> May affect human health and the environment if accumulated in water bodies 	USEPA, 2002
Chemicals of concern	Antibiotics and pharmaceutical chemicals	N/A	<ul style="list-style-type: none"> Widespread use of antibiotics to treat illness and promote growth may lead to antibiotic resistant pathogens Accumulation of pharmaceutical chemicals in water bodies may affect aquatic animals 	Mihelcic et al., 2011; USEPA, 2002

DO = Dissolved Oxygen NOD = Nitrogenous Oxygen Demand NH₄⁺-N = Ammonium as nitrogen

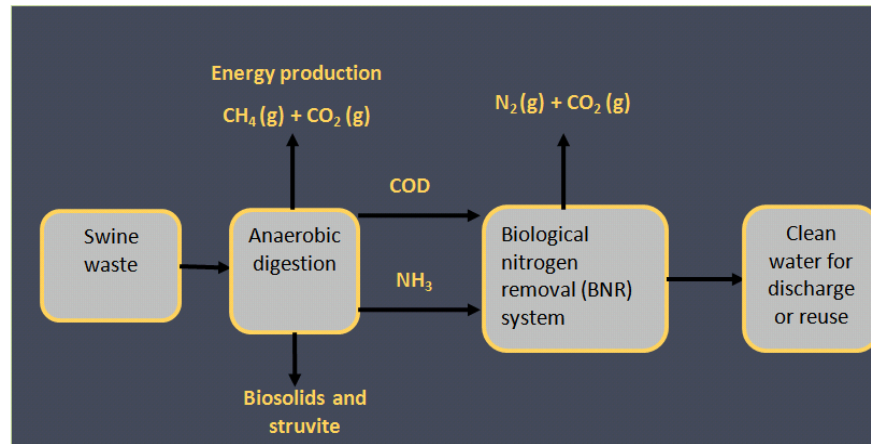

Figure 1.1 Schematic for proposed treatment of swine waste

Although AD is a potential solution to ALs, its effluent is rich in nutrients (N and P). Phosphorus can be removed and recovered through struvite precipitation. Struvite, which can be used as a fertilizer, is formed by reacting Mg^{2+} , PO_4^{3-} and NH_4^+ . Struvite precipitation lowers the concentration of total and soluble phosphorus in the effluent. Although struvite precipitation removes some of the total kjeldahl nitrogen (TKN) present in the centrate, further treatment is often required to more fully remove TKN (Rittman & McCarty, 2001).

This research investigates a novel physical, chemical, and biological treatment process that meets USEPA requirements and can be used by farmers for the treatment of swine waste. As shown in Figure 1.1, the process begins with the AD system for biogas production and COD reduction, followed by struvite precipitation and a biological nitrogen removal (BNR) system for nitrogen removal.

During the denitrification step of the BNR process, organic carbon is needed as an electron donor. However, due to efforts to maximize biogas production during AD, the effluent has a limited amount of bioavailable organic carbon that the denitrifying microorganisms need for respiration and growth (Mateju et al., 1992). Addition of an external carbon source may therefore be required. Unfortunately, this external carbon source increases the cost and complexity of operation. Moreover, oxidation of COD during nitrification decreases the COD/NO_3^- ratio available for denitrification. There is therefore a need to utilize a low cost technology that removes TN from AD effluent (Gaudy & Blachly, 1985). Some of the BNR processes that require little to no added organic carbon include Modified Ludzack-Ettinger (MLE) systems, Oxidation Ditch, 4-

stage Bardenpho, Zeolite Sequencing Batch Reactor (Zeo-SBR), SHARON/ANNAMOX and MAUREEN (Constantine et al., 2005; Nozhevnikova et al., 2012; Wei et al., 2010).

To solve the problem of providing an external carbon source, internal organic carbon from the AD effluent can be used during the denitrification step of the BNR. Operational parameters in the AD system, such as the organic loading rate (OLR) and solids retention time (SRT), affect the denitrification potential by using the biodegradable portion of the COD (C_S), which can be used as the internal organic carbon source. This thesis will therefore discuss the AD section of the process and the operating parameters that affect the concentration of C_S and NH_3 in AD effluent. The specific objectives of this research are:

1. To evaluate how different SRTs in the AD affect the denitrification potential of the centrate from the AD in a BNR process;
2. To offer guidelines on a favorable SRT for biogas production and methane yield, while providing adequate bioavailable organic carbon to provide an electron donor for denitrification;
3. To provide a critical literature review of how different operational parameters affect the performance of AD systems treating swine manure and
4. To perform a mass balance on the organic carbon and nutrients in an AD system.

CHAPTER 2: LITERATURE REVIEW

2.1 Anaerobic Digestion

AD is a process in which microorganisms stabilize and degrade organic material under anaerobic conditions. Biogas, stabilized biosolids, and liquid waste (referred to in this thesis as centrate) are the main byproducts of the process (Chen et al., 2008). AD is a natural process that occurs in living things and in soils and sediments, as microorganisms that favor anaerobic conditions (anaerobes) degrade organic matter. The anaerobic microorganisms assist in the carbon cycle (Chynoweth et al., 1999).

Engineered anaerobic treatment processes commonly used to treat livestock waste include anaerobic suspended growth, upflow anaerobic sludge blanket (UASB), AL, and fluidized-bed attached-growth bioreactors (Burton & Turner, 2003; Sakar et al., 2009). These engineered systems will be discussed later in this chapter.

2.1.1 Benefits of Anaerobic Digestion

AD is preferred over other systems, such as aerobic digestion, for treatment of livestock wastewater and industrial, and municipal sludges because of the advantages listed in Table 2.1.

2.1.1.1 Energy Production and Requirements

Unlike other waste treatment methods, such as aerobic digestion or combustion, AD is a net energy producing process (Appels et al., 2011; Tchobanoglous et al., 2003). Biogas produced by the anaerobic system contains 60-70% CH₄, 30-40% CO₂ and traces of H₂S, N₂ and H₂. Biogas can be utilized in combined heat and power (CHP) systems to

produce heat and electricity. Thermal and electrical efficiencies of these systems are 45% and 30%, respectively (Appels et al., 2011). As mentioned earlier, energy production is beneficial to the farmers, who can use it to heat their boilers, buildings, and reactors or can sell generated electricity.

Table 2.1: Benefits of Anaerobic Digestion

Benefit	Brief summary	Reference
Produces energy	AD is an energy-producing process. Biogas produced contains CH ₄ that can be utilized as an energy source.	Amani et al., 2010; Chen et al., 2008; Chynoweth et al., 1999; Tchobanoglous et al., 2003
Nutrient recovery	Biomass produced from the AD process is high in nutrients (TN and TP) that can be used to make cost-effective and sustainable fertilizer.	Chynoweth et al., 1999; Wilkie, 2005
Less biomass is produced than in aerobic systems	Because AD is an energy-producing process, very little energy goes towards cell growth of the microorganisms so less biomass is produced.	Nishio and Nakashimada, 2007; Tchobanoglous et al., 2003; Wilkie, 2005
Pathogens are destroyed	High temperature, long hydraulic retention times (HRT), and microbial competition in the reactor facilitate pathogen reduction.	Shin et al., 2011; Wilkie, 2005
Methane mitigation	Covered AD systems reduce CH ₄ emissions to the atmosphere. CH ₄ has a global warming potential (GWP) of 21.	Chynoweth et al., 1999; Mihelcic et al., 2011
Odor level lowered	An enclosed anaerobic digester assists in odor control.	Chynoweth et al., 1999; Wilkie, 2005

2.1.1.2 Biomass Production and Nutrient Requirements

Unlike aerobes that use oxygen (O₂) as an electron acceptor, anaerobes use fermentative metabolism or anaerobic respiration by consuming other electron acceptors such as sulfate (SO₄²⁻), CO₂, and nitrate (NO₃⁻) for their respiration. Anaerobic processes have lower energy yield, compared to using O₂ as the electron acceptor. In addition, during AD of livestock waste, the microorganisms degrade most of the organic solids to CH₄, CO₂, and other substances. These products are in the form of liquids and gases

(Nishio and Nakashimada, 2007), hence lowering the biomass produced. These favored characteristics of AD reduce operational time and cost that farmers would otherwise spend disposing of the biomass. Anaerobic systems produce up to 8 times less biomass than aerobic systems (Tchobanoglous et al., 2003).

2.1.1.3 Biogas Production and Methane Mitigation

Global climate change has been a concern for both scientists and governments around the world. CH₄ has a Global Warming Potential (GWP) of 21, which means that CH₄ GWP is 21 times greater than CO₂ GWP (Mihelcic et al., 2011). A 40-60% volatile solids (VS) reduction from AD of swine waste can produce 0.32 – 0.48 m³ CH₄/kg VS (Chynoweth et al., 1999). As mentioned previously, many CAFOs use ALs to treat their waste and uncovered ALs release CH₄ directly to the atmosphere rather than first oxidizing CH₄ to CO₂ through a combustion process.

2.1.1.4 Odor Reduction

Swine waste treatment methods, such as storage ponds and tanks, aerated, separate and combined treatment lagoons, have poor odor control (Choi, 2007). These systems favor anaerobic microorganisms; however, the low quantity of methanogens leads to an accumulation of volatile organic compounds (VOC). VOCs include volatile fatty acids (VFA), phenols, mercaptans, and carbonyls. H₂S and ammonia are also produced by sulfate reducing bacteria (SRB) and mineralization, respectively. These compounds have a low odor threshold, resulting in odor problems. Odor may be an aesthetic and nuisance problem and prolonged inhalation of these compounds may lead to respiratory health problems for both farm workers and animals (Chynoweth et al., 1999; Wilkie, 2005). A properly maintained and operated AD system will mainly produce CH₄

and CO₂, which are routed to combustion processes. Traces of odorous and corrosive H₂S in the biogas can be scrubbed before use (GTZ, 2010).

2.1.1.5 Pathogen Reduction

Raw CAFO wastes are known to contain pathogens such as *Salmonella*, *Clostridium perfringens*, *Campylobacter* spp., *E. coli*, and *Enterococcus* spp. that can pollute surface waters (Massé et al., 2011; Topp et al., 2009; Ziembra & Peccia, 2011). However, the environment in the AD systems helps to reduce pathogen concentrations. This is done through the HRT, temperature, and microbial community in the systems. Higher temperatures in thermophilic AD systems are known to have the best pathogen reduction. A 1-2 log inactivation of *E. coli* and *E. faecalis* was observed under mesophilic temperatures, but a 2-5 log inactivation under thermophilic temperatures during AD (Ziembra & Peccia, 2011). Inactivation occurs when pathogens lose viability when ribosomes are permanently damaged at temperatures greater than 55°C (Ziembra & Peccia, 2011). Since operating systems at high temperatures is not economical for farmers, increasing HRT in mesophilic systems can be a solution. While treating swine waste, longer HRTs in mesophilic AD systems led to better pathogen reduction because of increased contact between the pathogens and by-products such as VFAs and NH₃ (Massé et al., 2011). Pathogen concentration is also reduced due to either starvation or the pathogens are out competed by the other non-pathogenic microorganisms in the system (Wilkie, 2005).

2.1.2 Residual Nutrients

Effluent from anaerobic digestion cannot be directly discharged to a water body since residual organic matter, N, and P are present in high concentrations in AD effluent.

AD only has approximately 40-55% COD reduction and low P and N removal (Choi, 2007). A pig produces approximately 9 g P, 30 g N and 510 g COD per day, and these values can change depending on the pig's diet, temperature of the barn, and cleaning schedule.

Over-application of animal waste on farms has led to water and soil pollution. Instead of direct land application, AD effluents can be used to produce fertilizer. Reactive phosphate (orthophosphate) present in AD effluents can be lowered by adding Mg^{2+} to form struvite (Celen et al., 2007; Lin et al., 2012; USEPA, 2012). Equation 2.1 below illustrates struvite formation.



Struvite is a cost effective fertilizer that can meet plant phosphorus requirements and EPA's phosphorus application rate regulations (Burns & Moody, 2002; Celen et al., 2007). BNR systems can be used to remove the remaining NH_3 in AD effluents. These systems usually require aeration for nitrification and organic carbon addition for denitrification. The readily biodegradable COD present in the AD effluent can be used in as an internal organic carbon source for some BNR methods or external organic carbon sources such as methanol or acetate can be used for conventional nitrification/denitrification processes (Choi, 2007).

2.2 Microbial of Anaerobic Digestion

AD is a natural process that occurs when anaerobic microorganisms break down organic matter in the absence of O_2 . A simplified schematic of the four main anaerobic digestion steps (fermentation, acidogenesis, acetogenesis, and methanogenesis) and the microorganisms that lead to the production of CH_4 and CO_2 is shown in Figure 2.1.

Organic waste, such as swine waste, contains complex insoluble molecules, including proteins, carbohydrates, and lipids, which are converted to simpler soluble organic compounds by fermentation processes during AD. As shown in Figure 2.1, proteins are transformed into amino acids and sugars; carbohydrates are transformed into sugars, lipids are converted into fatty acids, alcohols, sugars, and amino acids; and lastly RNAs are transformed into purines and pyrimidines. This process is called hydrolysis and is carried out by fermentative bacteria (Amani et al., 2010). Hydrolysis is catalyzed by extracellular enzymes, such as cellulases, proteases and lipases (Masse & Droste, 2000). During hydrolysis, the degradation of recalcitrant compounds, such as lignin and cellulose, is a slow process. Therefore, depending on the type of waste and, on the lignin and cellulose concentrations, hydrolysis can be the rate-limiting step in AD (Amani et al., 2010).

In the second step, acidogenesis, simple soluble organic compounds, amino acids, sugars, alcohols, and fatty acids are further transformed into fermentation end products. Amino acids are transformed into acetate by fermentative bacteria. The acidogenic bacteria transform the sugars and fatty acids into volatile fatty acids (VFA), such as propionate, butyrate, and formate. These bacteria are known to have high growth rates in comparison to methanogens and can tolerate varying environments, such as increases in temperature, decreases in pH, and high loading rates (Amani et al., 2010). Acidogenesis products can be inhibitory to methanogens in an unstable anaerobic process (Chen et al., 2008).

Acetogenesis is the third step in the anaerobic digestion process. Volatile organic acids are further metabolized to acetate, formate, H₂, and CO₂ by H₂-producing

acetogenic bacteria (Amani et al., 2010; Wilkie, 2005). The partial pressure for H₂ has to be below 10⁻³ atm for the acetogenesis reaction to move forward and to ensure the acetogens are not inhibited (Khanal, 2009).

The fourth and final step in AD is methanogenesis. The methanogens and acetogens have a syntrophic relationship where the products of the acetogens are substrate for methanogens and the methanogens maintain the H₂ partial pressure below the level where it would inhibit the acetogens. There are two main active groups of methanogens, namely hydrogen-consuming and acetate-consuming methanogens as shown in Figure 2.1.

2.3 Microbial Relationships

The syntrophic relationship between methanogens and acetogens is crucial to AD performance. VFAs produced by the acetogens are utilized by methanogens to produce CH₄ and CO₂. However, the pH-sensitive methanogens can also be the rate limiting step in the process by slowly utilizing the acids formed by the fermenting acetogens. If the utilization of the acids is too slow it can cause the pH to decrease in the process (Amani et al., 2010; Rittman and McCarty, 2001). About 1,000-3,000 mg/L of alkalinity as CaCO₃ is required to maintain pH (6.5-8.0) at levels that do not affect the methanogens (Amani et al., 2010; Tchobanoglous et al., 2003). Addition of alkalinity increases operational cost of the AD system and can be reduced by lowering the OLR. If addition of alkalinity does not resolve the inhibition problem, feeding the anaerobic digesters can be stopped to allow the methanogens time to utilize accumulated VFAs (Amani et al., 2010; Tchobanoglous et al., 2003).

The H₂ consuming reaction is more thermodynamically favorable for methanogenesis than the acetate consuming reaction. This is because entropy is increased when one molecule of acetate forms two molecules of CH₄ and CO₂. Although H₂ consuming bacteria have better energy gains, anaerobic systems produce limited amounts of H₂ and acetate-consuming methanogens are more common producers of methane (Amani et al., 2010).

2.4 Stoichiometry of Anaerobic Digestion

Assuming that the empirical formula for biomass is C₅H₇O₂N, Eq 2.2 and 2.3 describe the stoichiometry of the fermentation stages of AD (green arrows in Figure 2.1) (Haandel & Lubbe, 2007):

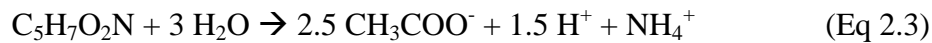

For every mole of livestock waste digested, 2.5 moles of acetate and 1 mole of ammonia are produced. During fermentation, H⁺ is produced, leading to alkalinity consumption. For every 113 g (1mole) of waste digested, 0.66 g of CaCO₃ is consumed. However, as the acetoclastic methanogens produce CH₄ from acetate (Eq 2.4), the H⁺ produced earlier is consumed. Thus alkalinity increases in the system. As shown in Eq 2.4, 0.44 g of CaCO₃ are produced for every 113 g (1mole) of waste digested.

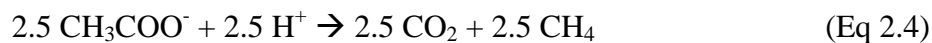

This production of alkalinity is enough to ensure that the system's pH stays within range required for the methanogens to produce CH₄ without inhibition. The overall anaerobic digestion process can be summarized by Eq. 2.5 (Haandel & Lubbe, 2007):



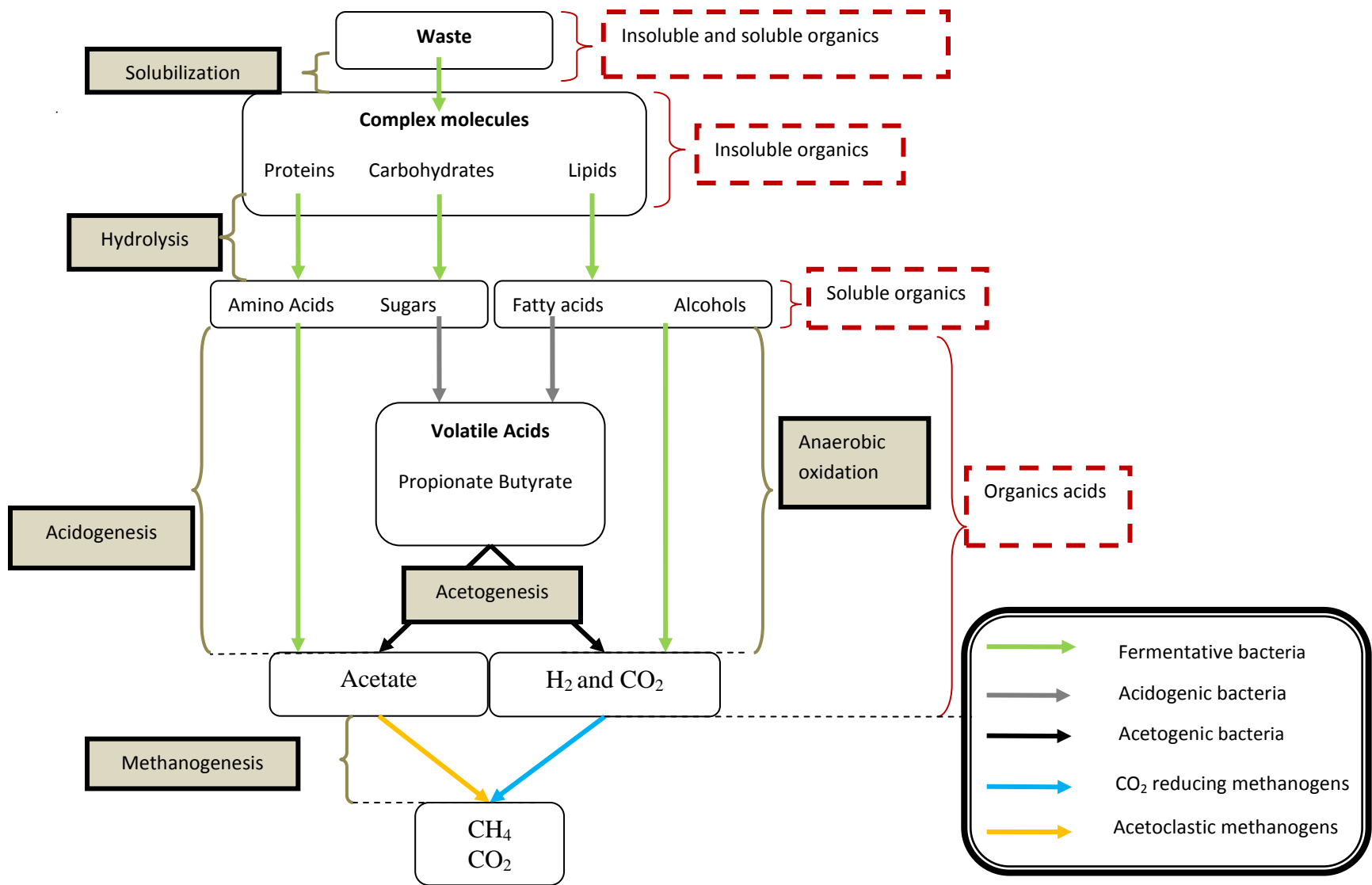

Figure 2.1: Anaerobic digestion process (Masse & Droste, 1999; modified)

2.5 Anaerobic Digestion of Swine Waste

Anaerobic reactors are mainly designed for VS removal and biogas production. To maximize VS removal and CH₄ yields at a reasonable cost, different operating parameters and reactor designs are considered. Factors that control the operating parameters and reactor design include influent characteristics, effluent quality desired, and biodegradability of the waste (Chynoweth et al., 1999). Table 2.2 is a summary of the operating parameters and performance of the three commonly used AD technologies (continuously stirred tank reactor (CSTR), upflow anaerobic sludge blanket reactor (UASB), and anaerobic sequencing batch reactor (ASBR)) used to treat swine waste.

2.5.1 Operating Parameters

Methanogens are strict anaerobes and, unlike the other microorganisms found in AD, they are the most susceptible to changes to the physical and chemical operating conditions of the system summarized in Table 2.3. These physical operating parameters include temperature, OLR, and HRT. The chemical parameters are pH, alkalinity, VFA concentrations, carbon nitrogen (C/N) ratio, nutrient concentrations (N and P) and toxicity (inhibition by NH₃ and hydrogen sulfide (H₂S)). These parameters are interconnected; a change in one parameter may affect the others positively or negatively. Maintaining the system under optimum conditions can be difficult. The physical and chemical operating parameters have to be analyzed periodically to ensure the process is working properly (Amani et al., 2010; Buekens, 2005; Burton & Turner, 2003; Gerardi, 2003; Sakar et al., 2009). For example a decrease in biogas production and/or methane content is a faster indicator of a malfunctioning system than changes in pH.

Table 2.2: Summary of operating parameters and performance of three commonly used AD technologies used to treat swine waste

Reference		Kaparaju & Rintala, 2005	Astrals et al., 2012	Deng et al., 2008	Sanchez et al., 1994	Ndegwa et al., 2005
Reactor Type		CSTR	CSTR	UASB	UASB	ASBR
Temperature	°C	35	N/A	20-25	35	35
Volume	L	3.5	4.0	15.0	6.8	12.0
HRT	d	N/A	20	3	N/A	4
<u>Influent</u>						
OLR	kg VS/m ³ -d	2.0	N/A	2.2 ^a	5.0-34.5	0.7
VFA	g/L	N/A	0.5-0.7	N/A	0.1-4.8	0.6
TS	g/L	60.0-78.0	21.5-21.8	N/A	5.6-58.0	3.6
VS	g/L	45.0-66.0	10.5-12.9	N/A	3.9-41.4	2.8
TN	g/L	N/A	N/A	1.0	N/A	N/A
TAN	gNH ₄ ⁺ -N/L	3.6-3.7	0.1	0.7	0.1-0.7	0.3
TP	g/L	N/A	N/A	0.1	0.2-1.5	0.07
<u>Effluent</u>						
VFA	g/L	N/A	0.1-0.2	N/A	0.1-0.8	0.2
COD reduction	%	72.0	49.0-56.0	82.0	12.1-58.0	73.0-88.0
TS reduction	%	33.0	21.4-21.8	N/A	22.5-44.3	N/A
VS reduction	%	33.0	36.0-41.0	N/A	12.8-52.3	N/A
TN	g/L	N/A	N/A	0.8	N/A	N/A
TAN	gNH ₄ ⁺ -N/L	N/A	120-180	0.8	0.2-0.6	0.5
TP	g/L	N/A	N/A	0.05	0.3-0.6	0.06-0.07
Biogas yield	m ³ CH ₄ /kg VS added	0.1 – 0.2	N/A	0.4 ^b	N/A	0.1 ^b

^a = kg COD/m³-d ^b = m³ CH₄/kg COD removed

Table 2.3: Summary of operating parameters for anaerobic digestion of livestock waste.

Parameters	Summary	Reference	
Physical	Temperature	Mesophilic: 30-35°C or Thermophilic: 50-55°C Methanogens prefer mesophilic temperatures but thermophilic systems have higher biogas yield and VS and pathogen reduction; however, are more sensitive to temperature changes and toxins.	Amani et al., 2010; Buekens, 2005; Gerardi, 2003
	OLR	Mostly expressed in terms of VS and affected by HRT, SRT, reactor volume, feeding and wasting rate. Optimal OLR range for most animals: 2.5-3.5 kg VS/m ³ -day.	Burton & Turner, 2003; Ozturk, 1999
	Retention times	HRT: reactor volume divided by flow rate; measure of the average time the waste is in the system. SRT: Measure of the average biomass in reactor divided by biomass wasting rate. SRT=HRT if no recycle/retention of biosolids. Temperature, feedstock, and waste characteristics affect retention times. Recommended minimum HRT/SRT: 10 days	Buekens, 2005; Sakar et al., 2009
	Biogas production and CH₄ yield	Related to OLR. CH ₄ yield is expressed as m ³ /kg VS added. Swine manure has a biogas yield of 0.34-0.55 m ³ /kg VS and a mean CH ₄ yield of 0.29 m ³ CH ₄ / kg VS _{added}	Burton & Turner, 2003; Chynoweth et al., 1999
Chemical	pH and Alkalinity	Methanogens cannot tolerate pH levels outside 6.8-8.5. Alkalinity regulates pH. pH is best adjusted by addition of bases such as CaCO ₃ , KCO ₃ and NaOH.	Amani et al., 2010; Buekens, 2005; Gerardi, 2003; Sakar et al., 2009
	VFAs	Precursors for CH ₄ production but inhibitory if they accumulate. Maximum recommended VFAs concentration is 2,000 mg/L as acetic acid.	Amani et al., 2010; Angelidaki & Ahring, 1993; Gerardi, 2003
	Inhibition	Free ammonia is the main cause of inhibition. Concentrations of NH ₃ , pH, temperature and acclimation are the main factors controlling inhibition. Maximum allowable NH ₃ levels range from 1.1 – 6.0 g N/L. H ₂ S concentrations greater than 200mg/L also cause inhibition.	Amani et al., 2010; Angelidaki & Ahring, 1993; Gerardi, 2003; Hansen et al., 1998; Whittmann et al., 1995

2.5.1.1 Temperature

AD microorganisms can survive at temperatures ranging from 0-82°C, but cannot tolerate temperature changes as well as aerobic microorganisms and prefer mesophilic and thermophilic temperatures (Amani et al., 2010; Buekens, 2005). Both mesophilic and thermophilic systems are heated above ambient temperatures to increase reaction rates compared to unheated systems. Although most AD systems are operated under mesophilic conditions (30-35°C), thermophilic temperatures (50-55°C) are better at reducing the concentration of organic matter by increasing the rate at which the volatile acids, such as propionate, are oxidized to acetate and H₂, which are later utilized by the acetoclastic and hydrogen consuming methanogens (de Bok et al., 2004). Thermophilic digesters require smaller volumes thus lowering capital costs. These systems can also tolerate higher OLR, and have better VS and pathogen removal rates than mesophilic systems (Zhang et al., 2000). Thermophilic reactors higher energy requirements for heating can be offset by using some of the biogas produced to heat the system.

Mesophilic systems are preferred to thermophilic systems for treatment of livestock wastes because they are not as sensitive and require less energy input (Gerardi, 2003). Thermophiles have high endogenous decay rates and cannot endure changes in the environment as well as the mesophilic microorganisms. A temperature change of less than 1°C/day affects thermophilic microorganisms more than a 2-3°C/day change in temperature for mesophilic microorganisms. Methanogens are not the only microorganisms directly affected by temperature changes in AD. High temperatures also increase the activity of the acidogenic bacteria. Accumulation of volatile acids can concurrently occur, which affects the methanogens.

The effect of temperature on VS removal has been investigated in several studies. In a two-stage ASBR system treating swine waste, performance of a 55°C reactor with an OLR of 4 kg VS/ m³-day, was compared to a 35°C reactor at an OLR of 1 kg VS/ m³-day. The thermophilic reactor had 6-15% better VS removal compared to the mesophilic reactor (Zhang et al., 2000). The same trend was observed by Ndegwa et al. (2005) who compared ASBRs at 20°C and 35°C. An increase in VS removal at higher temperature was attributed to an increase in biosynthesis rates as temperature increases.

2.5.1.2 Organic Loading Rate

AD is mainly used to lower the solids concentration of wastes, therefore the organic loading rate (OLR) is generally expressed in terms of VS. HRT, SRT, reactor volume, feeding and wasting rates and waste characteristics affect the OLR. Feeding a system at a high OLR can cause system instability, which can cause VFA accumulation. Acetogens and methanogens are both affected by overloading. During overload, the acetogens produce more acetate, which the methanogens are not able to utilize as fast as it is produced. Therefore gas production is lowered. CO₂ and H₂, the other products of acetogenesis (Figure 2.1), also accumulate in the system. As more H₂ is produced, the partial pressure of H₂ increases to more than 10⁻⁴atm. The slow growing methanogens are not able to utilize this H₂, hence lower biogas yields and lower CH₄ content in the gas. The acidogens may also experience inhibition with increasing H₂ partial pressure (Leitao et al., 2006).

VS concentrations differ between different livestock wastes, leading to differences in OLR based on the waste. There is therefore an optimal OLR for a system depending on the type of waste being treated. AD systems treating swine waste have been

operated at OLRs ranging from 0.9 to 15.5 g VS/L-day (Converse et al., 1977; Demirer & Chen, 2005; Hill & Bolte, 2000; Chen & Shyu, 1996; Zhang et al., 1997). However as OLR increases, biogas production, methane content and VS removal decreases for both mesophilic and thermophilic systems (Vandenburgh & Ellis, 2002; Husain, 1998). The recommended OLR for swine waste is 3.0-3.5 kg VS/m³-day (Burton & Turner, 2003; Ozturk, 1999).

2.5.1.3 Retention Time

HRT is the average time the waste is in the system and SRT is the average time the microorganisms are in the system. For systems with no biosolids recycle, SRT and HRT are the same. If the SRT is shorter than 10 days, the slow growing methanogens are washed out of the reactor. It is therefore crucial for the SRT to be greater than two times the generation time of the methanogens under the reactor conditions (Amani et al., 2010). HRT is also of concern when a system is being designed for optimal biogas production. The waste needs to be in the system for a minimum time for VS destruction and pathogen inactivation (Gerardi, 2003; Massé et al., 2011; Sakar et al., 2009). Retention times also affect the quality of effluent from AD. The residual organic carbon content changes depending on the time the microorganisms have to transform the substrate to biogas, which will be discussed in section 2.5.4.

Temperature, feedstock, and waste characteristics are all parameters that affect the retention times chosen for a system (Buekens, 2005; Sakar et al., 2009). The recommended HRT for swine manure is in the range of 10-20 days (Burton & Turner, 2003; Sakar et al., 2009). However HRT values out of this recommended range have been reported (Sakar et al., 2009).

2.5.1.4 Volatile Solids Reduction and Methane Yield

The rate at which biogas is produced is related to the rate of conversion of organic matter; usually in terms of VS or COD. Biogas production rate can be estimated in two ways, using a COD oxidation and reduction balance, or a material balance on the influent and effluent (Burton & Turner, 2003; Chynoweth et al., 1999). CH₄ yield is the preferred measure over biogas production because CO₂ in the biogas is not always related to degradation. A simple theoretical way to estimate CH₄ content (V) at standard pressure and temperature (STP), 1 atm and 20°C, uses the feed flow rate (Q) and the influent and effluent COD values (COD_i, COD_e). The empirical equation below can be used to calculate V, with the assumption that COD_i – COD_e accounts for the biodegradable portion of the waste (Burton & Turner, 2003):

$$V \text{ (m}^3\text{/d)} = 0.35 \text{ m}^3 \text{ CH}_4 / \text{kg COD (COD}_i - \text{COD}_e) \text{ (kg/ m}^3) Q \quad \text{(Eq 2.6)}$$

The actual CH₄ content of biogas is generally lower than this theoretical content because some of the influent COD is used for cell synthesis, some is dissolved in the effluent and compounds such as lignin affect the maximum biodegradability limit (Burton & Turner, 2003). Therefore, expressing CH₄ yield in terms of m³/ kg VS added is preferred. Sanchez et al. (1995), also treating swine waste, reported a maximum of 52% VS removal in a 6.8L UASB reactor. Sakar et al. (2009) found that the maximum VS removal for different AD systems treating swine waste was 61%, leading to a mean CH₄ yield of 0.3 m³CH₄/ kg VS added (Burton & Turner, 2003). This VS % removal is due to swine waste's composition. The waste is primarily made up of carbohydrates, proteins, cellulose and a small amount of lignin. Depending on the level of lignin (usually 4.4%) in

the waste, only about 60% of VS can be destroyed using AD technologies (Kaparaju & Rintala, 2005).

2.5.1.5 pH and Alkalinity

pH during AD is regulated by alkalinity (Amani et al., 2010; Buekens, 2005; Sakar et al., 2009). Alkalinity is the capability of water to neutralize an acid (Mihelcic et al., 2011). As the faster growing fermenting bacteria grow, they produce VFAs causing the pH in the system to drop if alkalinity is insufficient. As the methanogens utilize the VFAs to produce biogas, alkalinity is produced causing pH levels to stabilize. The amount of CO₂ in the biogas affects pH levels, as shown in Eq 2.7. Alkalinity concentrations below 3000 mg CaCO₃/L are a clear indication of system failure (Amani et al., 2010; Gerardi, 2003). This is usually caused by accumulation of VFAs, due to the slow conversion of the soluble organics (Figure 2.1) to volatile acids. Substances in the livestock waste that inhibit methanogens can also result in VFAs accumulation. For example, wastes with high levels of proteins lead to high alkalinity because of the rapid release of amino acids and NH₃. Alkalinity is expressed in the form of carbonate ions and these ions are in equilibrium with the CO₂ in the biogas. The pH is therefore affected by the equilibrium between the carbonate ions and NH₃, as shown in Eqs 2.7 and 2.8 (Gerardi, 2003).

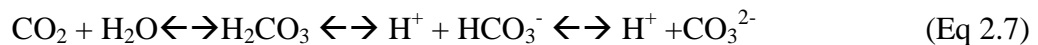

If the livestock waste does not contain enough alkalinity, alkalinity has to be added during the process to ensure the system maintains satisfactory pH and alkalinity values (Gerardi, 2003; Sakar et al., 2009). Alkalinity and pH also decrease during 1.) start up, as the methanogens slowly establish a community in the system, 2.) low HRT;

alkalinity is also lost as biomass is wasted and 3.) presence of inhibitory substances that affect methane forming microorganisms (Amani et al., 2010; Buekens, 2005; Gerardi, 2003; Sakar et al., 2009). Methanogens prefer bicarbonate alkalinity; therefore bases that discharge bicarbonate alkalinity such as sodium bicarbonate and potassium bicarbonate to adjust pH are recommended (Gerardi, 2003; Sakar et al., 2009).

2.5.1.6 Volatile Fatty Acids

VFAs are precursors to methane production and their accumulation has inhibitory effects on methanogens (Hill & Holmberg, 1988; Sakar et al., 2009). During AD of animal manure, VFAs, primarily acetic acid, are one of the parameters that are used to measure the performance of the system. As shown in Figure 2.1, acidogenic and acetogenic bacteria both produce volatile acids that are used by methanogens. Imbalances in these relationships lead to a decrease in pH from accumulation of VFAs. If this imbalance continues for a long period of time, acetogenic bacteria dominate the system, leading to complete failure. However if the system has sufficient alkalinity, pH will not decrease and undissociated VFAs will not inhibit methanogens (Sakar et al., 2009).

Ndegwa et al. (2005) observed that temperature and storage of waste affected VFA concentrations. This study found that a 15°C temperature decrease in an ASBR treating swine waste, lowered VFA concentrations from 0.1g COD/L to 0.04g COD/L and increased biogas production from 1.5L/day to 1.7L/day. However CH₄ yields decreased indicating that not all VFAs were transformed to CH₄ at lower temperature. In addition, the raw swine waste was stored at 4°C to avoid uncontrolled biodegradation before AD. Marti et al. (2008) attributed their high influent VFA concentrations (0.4g COD/L) due to prior fermentation of swine waste before digestion. Boursier et al. (2005)

observed higher VFA influent concentrations of raw swine waste. VFA concentrations increased from 7.0g COD/L to 11g COD/L as storage time, in ambient temperatures, increased which affected the effluent characteristics.

2.5.1.7 Inhibition

Despite the many advantages AD process can offer farmers treating their livestock waste, the relationship between the different microorganisms in the process can cause system failure due to production of inhibitory substances (Chen et al., 2008). Inhibition can either be acute, where microorganisms are suddenly exposed to a new inhibitor at high levels, or chronic, where the microorganisms are exposed to the inhibitor for a long period of time. During chronic inhibition, the microorganisms can restore the damaged enzymes and acclimate to utilize the toxin. New bacteria also grow that already have enzymes that are capable of degrading the toxin. This will depend on the microbial exposure time and concentration of toxin relative to biomass. As mentioned earlier, pH, alkalinity, VFAs and CH₄ yield can be used to indicate inhibition. NH₃ and H₂S are the main inhibitors affecting AD process treating livestock waste (Gerardi, 2003).

2.5.1.7.1 Ammonia

Ammonification occurs during AD due to the degradation of organic nitrogen compounds in the waste to generate total ammonia nitrogen (TAN), which exists as either ionized ammonium (NH₄⁺) or free ammonia (FA, NH₃), depending on pH (Eq 2.9) (Im & Gi, 2011; Tchobanoglous et al., 2003).

$$FA = \frac{TAN \times 10^{pH} \times \frac{17}{14}}{e^{\frac{6344}{(273+T)}} + 10^{pH}} \quad (\text{Eq 2.9})$$

FA is the main inhibitor for AD systems because it passes through the microorganisms' cell membrane, leading to a proton imbalance and potassium deficiency (Amani et al., 2009; Chen et al., 2008; Gerardi, 2003). The changes in the cells, once the microbes are exposed to high levels of NH_3 , is what causes inhibition. These cell changes include: 1.) change in pH within the cell, 2.) important enzymatic reactions are not carried out due to inhibition and 3.) cells' energy requirement for maintenance increases (Wittmann et al., 1995). Of all the microbes in the AD process, methanogens are the most susceptible to NH_3 inhibition. Maintaining the pH between 6.8 and 7.2 can ensure the system is working properly. Decreasing the pH, for example from 7.5 to 7 has been shown to improve CH_4 content (Zeeman et al., 1985). pH levels have to be maintained in a range that is optimal for methanogens and acidogens to lower chances of system failure (Chen et al., 2008). Other factors influencing FA inhibition include: TAN concentrations, temperature, other ions present and acclimation (Chen et al., 2008; Im & Gil 2011).

Levels at which TAN concentrations are inhibitory to methanogens vary in literature. Hansen et al. (1998) and Troyer et al. (1997), both treating swine manure, observed inhibition at 1.1 g N/L and 1.7-2.3 g N/L respectively, while Zhang et al., (1997), also treating swine manure, observed inhibition at 2.5 g N/L. Magbanua et al. (2001) co-digested hog and poultry manure and found a TAN maximum level of 5 g N/L. Although Kaparaju & Rintala (2005) reported TAN concentrations of 1.5-2.5 g N/L, which is within the inhibitory range, their CSTR was not inhibited. This was because their FA concentrations (0.2-0.3 g N/L at pH 7.9) were lower compared to other literature where FA concentrations of 0.7-1.1 g N/L had inhibited AD of livestock wastes (Angelidaki & Ahring 1993; Hansen et al., 1998)

Temperature is another factor controlling FA inhibition (Eq 2.9). An increase in temperature leads to higher growth rates for the microorganisms, but also leads to an increase in FA levels and lower CH₄ yields (Hansen et al., 1998). FA and ions, such as Ca²⁺, K⁺, Na⁺, Mg²⁺, have an antagonistic relationship during AD, where the toxicity of one is lowered by the presence of the other (Amani et al., 2010; Chen et al., 2008). One possible explanation is that these cations are able to combine or exchange with FA leading to lower inhibition (Krylova et al., 1997).

FA inhibition can be decreased by diluting the manure to a recommended TS concentration of 0.5-3.0%. However, dilution increases the volume of waste to be treated, which is not economically attractive to farmers. Using static material, such as activated carbon, glauconite and zeolite to immobilize biomass has been shown to reduce FA inhibition and stabilize CH₄ yield through ion exchange (Chen et al., 2008).

2.5.1.7.2 Sulfide

During AD, SRB reduce sulfate (SO₄²⁻) to sulfides (Eq 2.10), which exists as either unionized H₂S gas or soluble ionized sulfide (HS⁻) depending on pH (Eq 2.11) (Tchobanoglous et al., 2003). SRB either oxidize lactate to acetate and CO₂ or acetate to CO₂ and HCO₃⁻. During microbial cell growth, small amounts of HS⁻ are utilized as a nutrient. Sulfide inhibition occurs when SRB compete with other microorganisms for insoluble and soluble organics and when they produce high concentrations of sulfides that can be toxic to AD microorganisms (Chen et al., 2008). Acetoclastic methanogens and acidogenic bacteria are the most sensitive to sulfides. H₂S is mainly responsible for inhibition because its molecules have the capability to diffuse into the cell faster than

HS⁻, hence disrupting the cells' enzyme activity. Inhibition occurs at neutral pH at H₂S concentrations greater than 0.2 g/L (Gerardi, 2003).

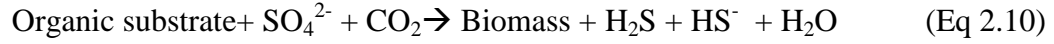

COD/SO₄²⁺ ratio (anaerobic community versus SRB community) is a factor in controlling H₂S inhibition. For every 1.0 g of COD degraded, 1.5 g of SO₄²⁺ is reduced to H₂S. COD/SO₄²⁺ ratios below 1.7 have been shown to inhibit AD microorganisms. Methanogens dominate at COD/SO₄²⁺ ratios above 2.7 (Chen et al., 2008). Diluting livestock waste and scrubbing biogas to remove free H₂S from the reactor gases are all feasible solutions to H₂S inhibition (Chen et al., 2008; Gerardi, 2003).

2.5.2 Anaerobic Reactors and Technologies

Reactors for AD of livestock waste must be designed in a way that facilitates the microorganisms' activities while meeting farmers' needs. Design components for agricultural digesters are shown in Figure 2.2. Reactors designed to treat livestock wastes in the developed world have two different operating modes; batch or continuous. A summary of the operational modes for AD is given in Table 2.4 and schematics reactors that are mainly used to treat animal waste are shown in Figure 2.3. Schematics of small scale AD systems used in the developing world are shown in Figure 2.4.

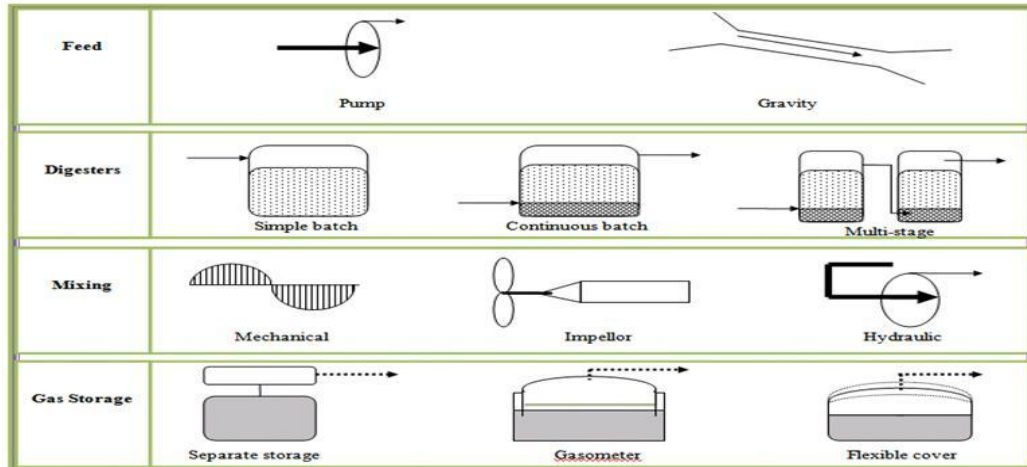

Figure 2.2: Agricultural AD components (Burton & Turner, 2003; modified)

Table 2.4: Summary of AD operation modes (Burton & Turner, 2003)

Operation mode	Examples	Summary
Batch	Anaerobic sequencing batch reactor (ASBR)	Fresh manure is fed into the reactor and digested with ~ 10% of the sludge from the previous batch. Batch cycles can take up to 4 weeks to degrade waste until maximum biogas production is met. 3-4 batches are operated at the same time but each is fed on different schedules.
Continuous	Continuously Stirred Tank reactor (CSTR) and Upflow Anaerobic Sludge Blanket (UASB)	The most common type of reactors for livestock waste. Equal influent and effluent flow. Steady state systems with long HRT of up to 30 days. Feeding frequency depends on substrate characteristic.

2.5.2.1 Developed World Processes

2.5.2.1.1 Continuously Stirred Tank Reactor

In the CSTR process the SRT is the same as the HRT since there is no biomass recycle. This is especially vital for wastes with a high solids concentration, where recycling would overload the system. Detention times can range from 10 to 30 days, to

avoid the washing out of microorganisms. The OLR required depends on the waste characteristics as discussed previously. Mixing in these reactors also ensures that microorganisms are in constant contact with the wastewater and there is no settling of non-degradable material, such as sand. Part of the CH₄ gas produced can be utilized to operate boilers that are used to heat the reactors, making the process more cost effective (Tchobanoglous et al., 2003; Rittmann and McCarty, 2001). CSTR systems have been used successfully to treat swine waste at OLRs of 2.0-3.0 kg VS/ m³-day to produce CH₄ yields of 0.1-0.3 m³ CH₄/ kg VS (Hansen et al., 1998; Kaparaju & Rintala, 2005)

2.5.2.1.2 Anaerobic Sequencing Batch Reactor

The ASBR process consists of four steps. The first is the feeding step followed by the react step. During the react step, mixing is done periodically to ensure a homogenous solution. The mixing is not continuous as in the CSTR to allow for settling. During the settle step; the speed at which the biomass settles affects the effluent quality of the following decant step; 30 minutes of settling is adequate for a properly functioning system (Tchobanoglous et al., 2003). This system has been used to treat swine waste to produce CH₄ yield of up to 0.11 m³ CH₄/ kg COD (Ndegwa et al., 2005)

2.5.2.1.3 Upflow Anaerobic Sludge Blanket Reactor

The basic UASB process is designed to have the wastewater feed from the bottom of the reactor. The wastewater moves through a layer of granular sludge (sludge blanket), where the microorganisms carry out biodegradation. The effluent is released from the sides at the top while the biogas is collected in a special gas collector at the middle. Better quality effluent is achieved with longer HRTs. Granules found in the reactors are formed by the group of microorganisms (fermenters, acidogens, acetogens and

methogens) that go through the anaerobic digestion. These granules take weeks to form hence reactors are often seeded with granular sludge from an already acclimated UASB. Therefore, the longer HRTs produce better effluent quality. Granule formation is affected by the OLR and the speed at which the wastewater moves through the reactor (Tanaka & Suzuki, 2004; Tchobanoglous et al., 2003).

When designing a UASB reactor, the solids concentration, OLR, upflow velocity and volume are considered. If the wastewater has a high concentration of solids, the granules essential for the process are not formed as well. For total suspended solids (TSS) concentrations greater than 6.0 g/L, either CSTR or ASBR will be better alternatives. The OLR and temperature affect the effluent quality. UASB reactors can handle OLRs of up to 15kg COD/m³-day (Tchobanoglous et al., 2003). The velocity of the wastewater depends on the cross sectional area of the reactor as well as the soluble portion of the COD. If all of the COD is assumed to be soluble, 1.5 m/h is the average velocity used, while 1.0 m/h can be used for partly soluble COD. The treatment volume, which is the volume of the sludge blanket with active granules, is based on the velocity, OLR and target effluent characteristics (Tchobanoglous et al., 2003; Rittmann and McCarty, 2001). One benefit of using UASB as compared to CSTR is it requires a lower HRT while achieving up to 75% COD removal (Kalyuzhnyi et al., 1999; Tanaka & Suzuki, 2004).

2.5.2.2 Developing World Processes

There are three commonly used small scale anaerobic systems in the developing world: fixed dome, floating drum and polyethylene tubular digesters. The choice of digester depends on cost and availability of construction material, temperature of the region, amount of waste to be treated, operation and maintenance and level of skill in the

community. The feeding schedule for the digesters also needs to be considered. Batch or continuous digesters can be used; however, continuous digesters are preferred because they automatically empty by overflowing (GTZ, 2010).

2.5.2.2.1 Fixed Dome Digester

This type of digester has three main sections, as shown in Figure 2.4. Section 1 is a tank where a mixture of manure and water is poured and flows through a pipe to Section 2, the fixed digester. As the anaerobic process occurs in the fixed digester, the biogas produced creates a pressure that pushes some of the treated waste (slurry) into a third section, known as the biomass removal tank. The biogas is stored within the fixed digester, which must be gas tight. A gas pipe is connected to a rigid gas storage tank, to allow release of biogas when needed (Ocwieja, 2010; Kossmann et al., 1999). Fixed dome digesters have been used in Pachacámac, Lima to treat animal manure and the biogas is stored in used car tire tubes (Ferrer et al., 2009).

The fixed dome digester is low cost, has no metal parts that easily rust, is usually built underground and thus saves space, and has been known to last as long as 20 years. The disadvantage with this digester is that skilled laborers are required for its construction. Its temperature is usually low and biogas volume changes affect the gas pressure leading to burner malfunction (Kossmann et al., 1999).

2.5.2.2.2 Floating Drum Digester

The design of the floating drum is very similar to the fixed dome, but has a moving gas storage tank, as shown in Figure 2.4. The floating drum is supported by a guiding frame and the tank rises and falls depending on biogas production and use. The drum floats on top of the digesting slurry or on a water jacket. Materials such as plastic

reinforced with fiberglass and high density polyethylene can be used for constructing the drum. PVC is not recommended as it does not resist UV light (Kossmann et al., 1999).

The floating dome is simple to operate and often preferred due to the visible evidence of biogas. Gas pressure is constant and it does not require skilled labor for its construction. The floating drum does; however, increase the initial cost and lowers its life to about 15 years, or 5 years in tropical regions due to corrosion of parts. It also requires more maintenance. Even with these disadvantages, the floating drum is preferred over the fixed dome and is widely used in India (Kossmann et al., 1999; Ocwieja, 2010).

2.5.2.2.3 Polyethylene Tubular Digesters

These digesters also known as balloon digesters and are constructed from semi-elastic plastic or rubber bags, as shown in Figure 2.4. Tubular digester are placed in a 2.0-5.0% slope trench and operated much like a fixed dome digester with a separate biogas storage tank. They cost the least compared to the other digesters, are operated at high temperatures, but are easily damaged and last the shortest time; a maximum of 10 years (GTZ/EnDev, 2010). Household plug flow tubular digesters to treat animal manure were implemented in the Peruvian Andes with a HRT of 90 days and an inside temperature of about 25°C. These systems produced 2-3 hours of biogas for cooking each day (Ferrer et al., 2010).

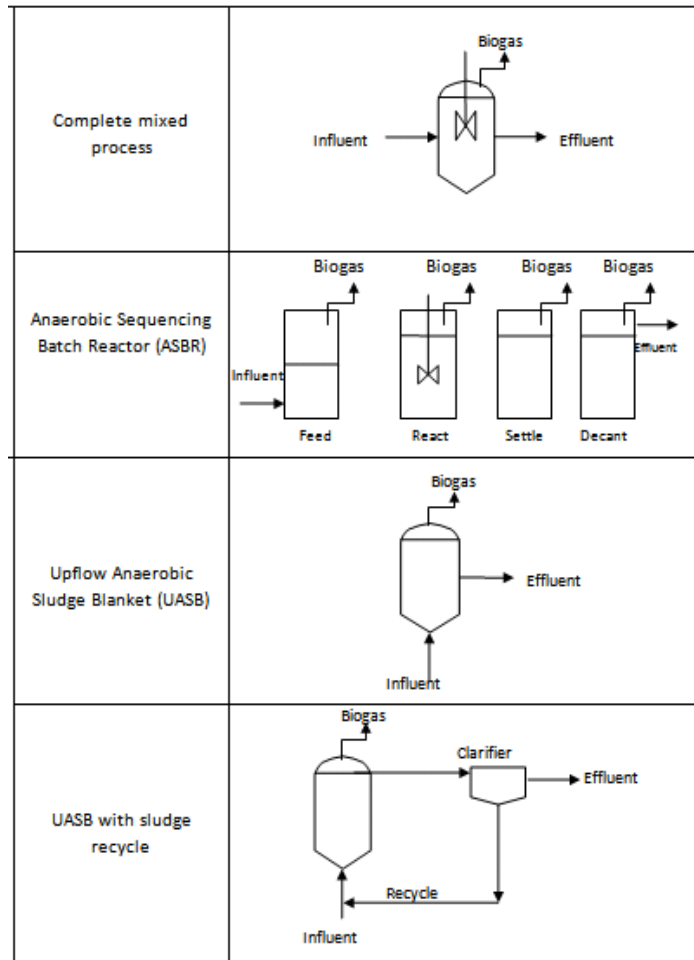

Figure 2.3: Anaerobic processes and reactors (Tchobanoglous et al., 2003; Rittmann and McCarty, 2001; modified)

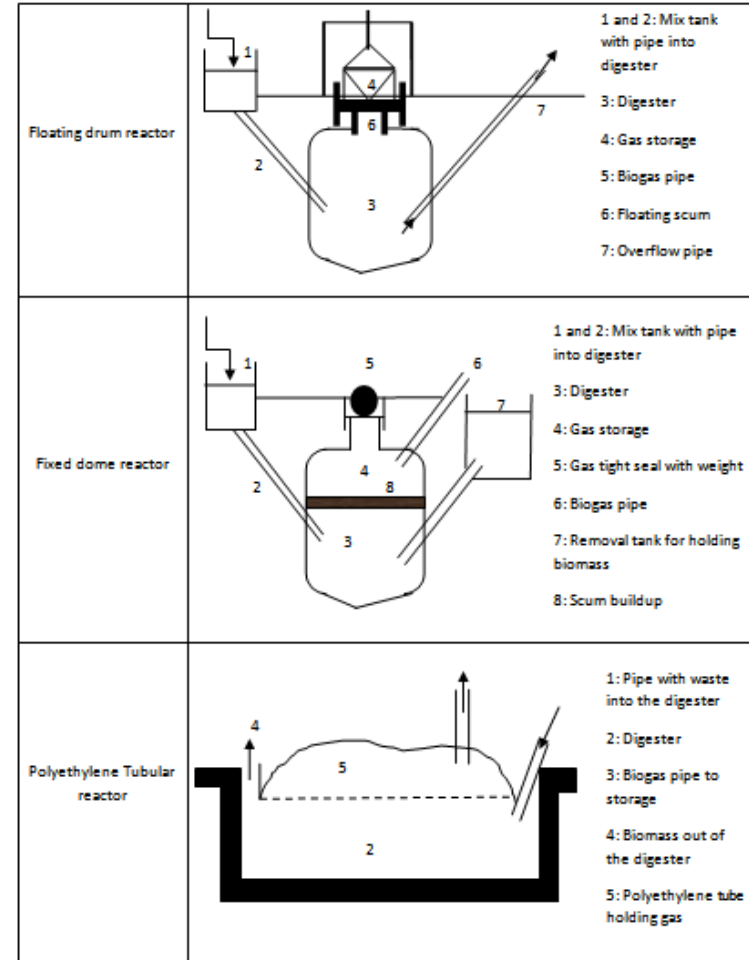

Figure 2.4: Small scale anaerobic digesters (GTZ, 2010; modified)

2.6 Organic Carbon in Wastewater

The term COD encompasses different fractions of organic carbon in raw and treated wastewater. These different portions can be differentiated depending on their physical state (dissolved, particulate) and biodegradability. Fractionation of COD will be discussed in terms of the influent (raw) and effluent (treated) wastewater. Assessment of these COD fractions and denitrification potential will also be discussed.

2.6.1 Influent COD

Influent COD in the AD system is divided between total biodegradable (C_S) and total non biodegradable (C_I) portions, as shown in Figure 2.5. Total non biodegradable COD is subdivided into particulate inert (X_I) and soluble inert (S_I) COD. Inert COD does not affect or go through any biological processes occurring in the system and both particulate and soluble inert COD are removed as part of the effluent during wasting (Dold & Marais, 1986; Orhon & Çokgör, 1997; Tchobanoglous et al., 2003). Total biodegradable COD is subdivided into slowly biodegradable (X_S) and readily biodegradable (S_S) COD. These divisions are based on biological, and not physical, characteristics (Dold & Marais, 1986; Wentzel et al., 1995). Slowly biodegradable and readily biodegradable COD are utilized by cells for biosynthesis; however, the rates at which cells utilize them are different (Dold & Marais, 1986). Readily biodegradable COD consists of fermentable COD (S_F) and fermentation products (S_A). Fermentation products include acetate, propionate and other organic acids, which are produced during AD (Orhon & Çokgör, 1997). Slowly biodegradable COD is comprised of different sized particles that cannot pass through cell walls. In order to be adsorbed by the cells, extracellular hydrolysis is necessary, hence the rapidly hydrolysable (S_H) COD and

slowly hydrolysable (X_{SH}) COD portions of slowly biodegradable COD (Dold & Marais, 1986; Wentzel et al., 1995). Therefore, depending on particle size of the waste, hydrolysis can be the rate limiting step in AD. This is because these organics need to be broken down for easier adsorption (Angelidaki & Sanders, 2004; Elmitwalli et al., 2001; Vavilin et al., 1996). Utilization of rapidly hydrolysable COD is dependent on the type of waste being treated (Henze, 1992). Vavilin et al. (1996) found that swine and cattle waste both had a hydrolysis constant of 0.3/day while cellulose had a 0.1/day hydrolysis constant.

2.6.2 Effluent COD

The COD distribution in the effluent is shown in Figure 2.6. AD effluent COD (S_T) characteristics differ from influent COD (C_T). Total effluent COD includes S_I ; soluble but non biodegradable inert portion that was present in the influent, soluble inert residual products (S_P), rapidly hydrolysable (S_H), and readily biodegradable (S_S); soluble residual portions of total biodegradable COD (C_S). The COD in the effluent mainly consists of soluble but inert COD portions. Soluble residual products, also known as soluble microbial products (SMP), are formed by biodegradation of organics during microbial biosynthesis (Duran & Speece, 1999).

The insoluble/ particulate portion of effluent COD also have to be considered in COD fractionation. Figure 2.7 illustrates particulate COD distribution in the effluent. Total particulate COD comprises of slowly biodegradable COD, active biomass (X_H), particulate inert products from death and decay of microorganisms and particulate inert COD (X_I) which is trapped in the biomass and accumulates in the reactor. When in the system, the active biomass part of the particulate COD, utilizes total biodegradable COD

for heterotrophic growth. Active biomass utilization of total biodegradable COD affects the availability of readily biodegradable COD if the effluent is to be utilized for BNR (Lu et al., 2010; Mathieu et al., 2001; Wentzel et al., 1995). Due to slow hydrolysis rates in AD, some of the slowly biodegradable COD is still in particulate form in the effluent and contributes to the total particulate COD. Lastly, inert organic products from endogenous decay and death of the microorganisms contribute to particulate COD in the effluent (Orhon & Çokgör, 1997).

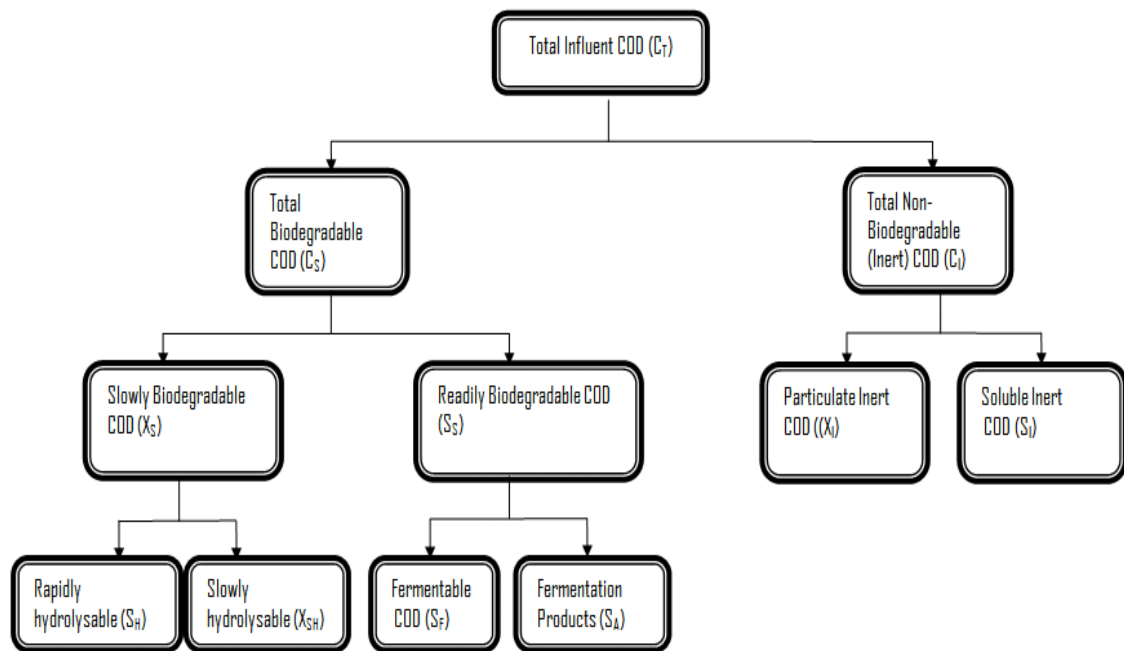

Figure 2.5: Total influent COD fractionation (Orhon & Çokgör, 1997; Tchobanoglous et al., 2003 modified)

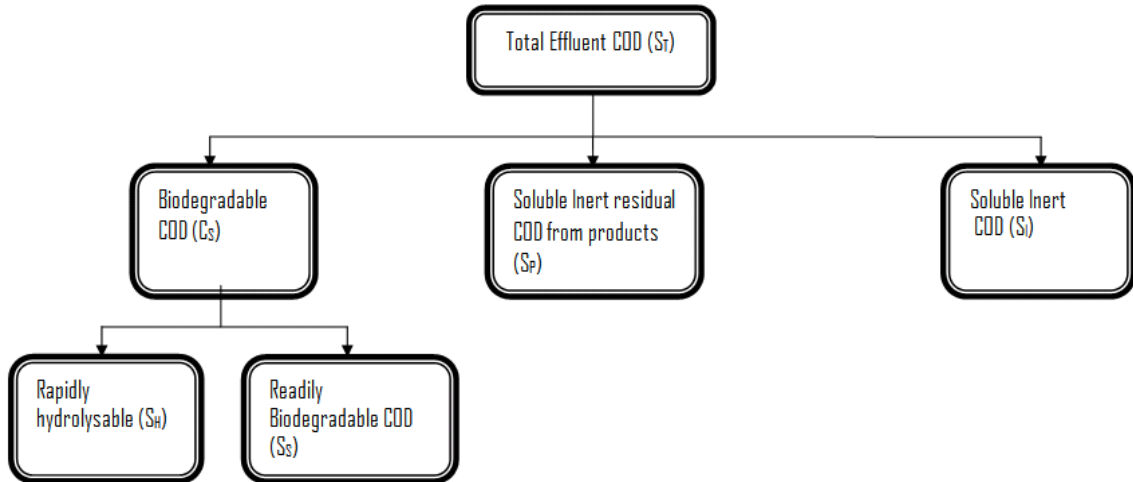

Figure 2.6: Total effluent COD fractionation (Orhon & Çokgör, 1997 modified)

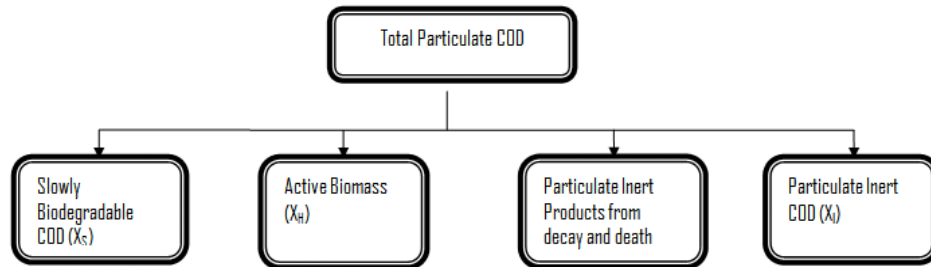

Figure 2.7: Total influent particulate COD fractionation (Orhon & Çokgör, 1997 modified)

2.6.3 Assessment of COD Fractions

For further treatment of AD effluent using BNR processes, the organic fractions in the effluent needs to be identified, to evaluate its biological treatability. Readily and slowly biodegradable COD, microbial products, and inert COD fractions will be discussed in this section of the paper.

2.6.3.1 Readily Biodegradable COD (S_S)

Readily biodegradable COD quantity affects both nitrogen and phosphorus removal in subsequent BNR systems (Lu et al., 2010; De Lucas et al., 2000; Mathieu et al., 2001; Wentzel et al., 1995). At high readily biodegradable COD values,

denitrification and biological phosphorus removal rates are higher (De Lucas et al., 2000; Tchobanoglous et al., 2003). While hydrolysis is sometimes considered the rate limiting step for AD, depending on waste particle size, readily biodegradable COD is the rate limiting component for denitrification (Orhon & Çokgör, 1997). Both aerobic and anoxic respirometer tests have been used for measuring readily biodegradable COD in AD effluent (Çokgör et al., 1998; Ekama et al., 1986; Lu et al., 2010; De Lucas et al., 2000; Orhon & Çokgör, 1997).

The aerobic test, measures the oxygen consumed, or oxygen uptake (OU) by aerobic heterotrophs over time per volume of testing vessel. Depending on the food to microorganism ratio (F/M), OU, for the first 1-3 hours is constant because of the availability of readily biodegradable COD to facilitate microbial growth. If nitrification is allowed, a second plateau is observed for OU due to nitrification. A decrease in OU then occurs to accommodate oxidation of slowly biodegradable COD. This process is limited by aerobic hydrolysis of COD. Once all total biodegradable COD is utilized, OU observed is associated with respiration due to endogenous decay of microorganisms (Çokgör et al., 1998; Melcer et al., 2003; Orhon & Çokgör, 1997). An oxygen uptake rate (OUR) profile indicating how these regions are developed is illustrated in Figure 2.8.

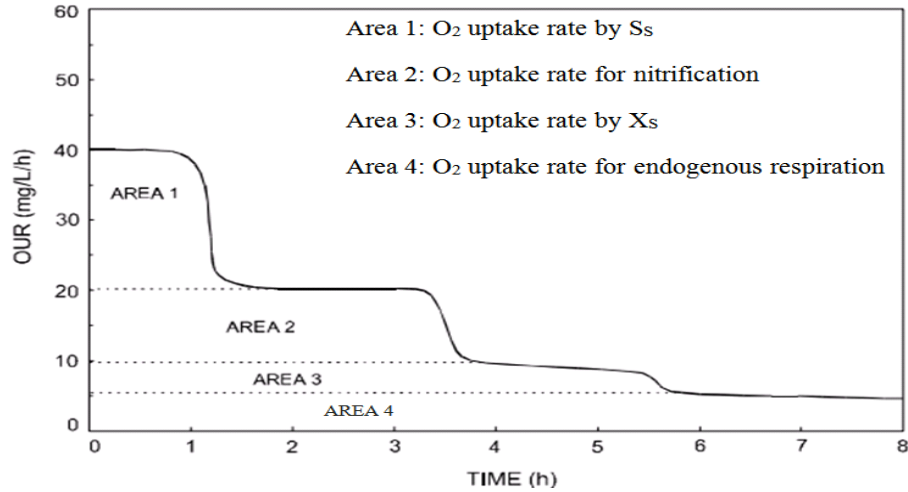

Figure 2.8: OUR profile for aerobic batch test (Melcer et al., 2003; modified)

Readily biodegradable COD is calculated by estimating Area 1 and applying Eq 2.12 (Ekama et al., 1986; Melcer et al., 2003).

$$S_S = \frac{1}{1 - f_X Y_{HET}} \cdot \text{Area 1} \cdot \frac{V_{SL} + V_{WW}}{V_{WW}} \quad (\text{Eq 2.12})$$

where:

Area 1 = mass of O₂ consumed per liter of volume for S_s utilization (mg O₂/L)

Y_{HET} = yield coefficient for heterotrophic microbes (0.66 mg cell COD/mg substrate COD)

f_X = F/M ratio (mg substrate COD/mg microorganisms VSS)

V_{SL} = volume of activated sludge VSS (L)

V_{WW} = volume of wastewater of S_T (L)

Readily biodegradable COD can also be estimated under anoxic conditions by measuring the initial NO₃⁻-N utilization rate. The basis of the nitrate uptake rate (NUR) test is similar to the OUR; however, NO₃⁻ is the electron acceptor instead of O₂. NO₃⁻ is

added to the test vessel and a NUR profile (Figure 2.9) is obtained by either measuring NO_3^- concentration or N_2 produced over time. The initial NO_3^- conversion to N_2 gas by utilizing readily biodegradable COD is usually fast, because heterotrophic growth occurs at high rates in the presence of high readily biodegradable COD concentrations. Once the microbes utilize readily biodegradable COD, denitrification rate slows down as slowly biodegradable COD is transformed to readily biodegradable COD for the microorganisms' utilization; hence the second plateau in Figure 2.9 (Ekama et al., 1986).

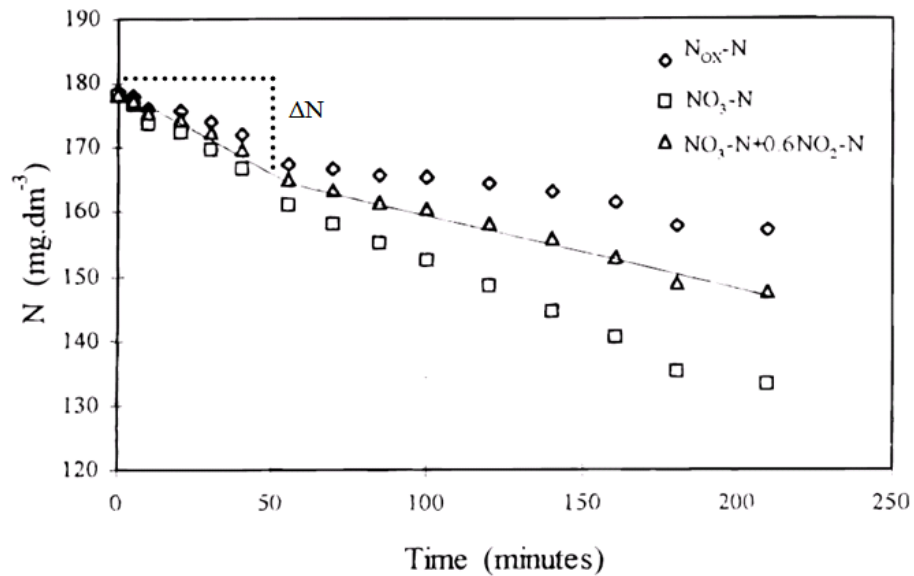

Figure 2.9: NUR profile for anoxic batch test (Orhon & Çokgör, 1997; modified)

S_S is calculated by estimating the ΔN and applying Eq 2.13 (Ekama et al., 1997).

$$S_S = \frac{2.86}{1 - f_X Y_{HET}} \cdot \Delta N \cdot \frac{V_{SL} + V_{WW}}{V_{WW}} \quad (\text{Eq 2.13})$$

where:

ΔN = mass of NO_3^- consumed per liter of volume for S_S utilization (mg N/L)

2.6.3.2 Slowly Biodegradable COD (X_S)

Slowly biodegradable COD consists of hydrolyzing products that are biodegradable (Ekama et al., 1986). Slowly biodegradable COD is estimated using model mass balances. If the hydrolysable fractions are not included in the mass balance, Eq 2.14 can be used to estimate X_S . If rapidly and slowly hydrolysable COD soluble fractions are included in the mass balance; Eq 2.15 and 2.16 can be used to measure them (Orhon & Çokgör, 1997).

$$C_S = S_S + X_S \quad (\text{Eq 2.14})$$

$$S_H = S_T - S_I - S_S \quad (\text{Eq 2.15})$$

$$X_{SH} = X_T - X_I - X_S \quad (\text{Eq 2.16})$$

While investigating COD fractionation, Boursier et al., 2005 found that swine waste contained high concentrations of very slowly hydrolysable X_S that could not be identified during a 24 hour respirometer test. While using Figure 2.8, areas 3 and 4 were difficult to distinguish. They attributed this phenomenon to the HRT of the AD that affected total hydrolysis of the swine waste.

2.6.3.3 Inert COD Fractions and Microbial Products

There is contradicting literature on the biodegradability of SMPs and SRT influence on their production. Kuo et al. (1996) defines SMPs as partially biodegradable and an increase in SRT increases SMPs. Biomass associated products (BAP), part of SMPs, increase because microorganisms have more time to degrade the waste. Duran & Speece (1999); however, define SMPs as effluent organics that cannot be biologically transformed and according to Chudoba (1985), the inert portion of COD indirectly affects the biodegradability of the organic carbon that microorganisms utilize for growth. The soluble inert/ refractory COD (S_I) in the influent is related to the growth independent and

growth dependent products, such as SMPs, that contribute to the biodegradability of the effluent. However, soluble inert COD concentrations are so low that they do not contribute much to the biodegradable portion of the effluent COD. Moreover, in natural aquatic systems, soluble inert COD does degrade eventually but at extremely low rates.

2.6.4 Denitrification Potential

Denitrification, also known as dissimilatory nitrate reduction (DNR), is a four step respiratory metabolism (Eq 2.17). Denitrifying bacteria are either heterotrophs, that utilize organic carbon as the electron donor for respiration, growth and energy (Eq 2.18), or autotrophs that utilize H₂ (Eq 2.19) or reduced sulfur compounds such as S⁰ and SO₃²⁻ (Birgand et al., 2007; Mateju et al., 1992; Sun et al., 2009). There are several factors that influence the denitrification potential of wastewater. These include the concentration and bioavailability of organic carbon, temperature, DO, and pH (Choi, 2007). Only organic carbon's influence on heterotrophic denitrification rates will be discussed in this thesis.



Although there is limited literature on the denitrification potential of anaerobically digested swine waste, prior studies agree that the rate of denitrification in a BNR system is influenced by C_T to NH₄⁺-N ratio. NH₄⁺-N concentration is used assuming that all the NH₄⁺-N will be converted to NO₃⁻ during the BNR process. However, only the total biodegradable COD portion is available for denitrifiers to convert NO₃⁻ to N₂. It is therefore more accurate to calculate the C_S/ NH₄⁺-N ratio (Boursier et al., 2005; Magrí & Flotats, 2008). For efficient denitrification (>90% NO₃⁻ removal), a C_S/ NH₄⁺-N ratio of 2.9 g COD/ g N is required; however, due to biosynthesis and endogenous respiration of

organic matter, a ratio >5.0 is required for swine wastewater (Boursier et al., 2005; Choi 2007). VFAs from AD effluent treating swine waste have been used as an organic carbon source for BNR systems. However due to the low C_S/ NH_4^+-N ratio (0.7), addition of acetic acid was required to achieve 99% $NO_3^- -N$ removal (Obaja et al., 2005). To improve denitrification potential from an internal carbon source, the authors suggested using raw swine waste that had higher readily biodegradable COD values than AD effluent.

Certain conditions, before and during operation of AD, affect the bioavailability of total biodegradable COD in the effluent. These include; waste and farm management practices, and SRT of AD. Magrí & Flotats (2008) evaluated the denitrification potential of the liquid portion of pig slurry from an AD system and reported a C_S/ NH_4^+-N ratio of 3.9. They attributed the low biodegradability value to uncontrolled degradation of the pig waste while on the farm. Boursier et al. (2005), investigated how samples of pig waste collected at different storage times at the same farm varied in bioavailability of organic carbon for denitrification. At longer storage times, the C_S/ NH_4^+-N ratio was lower. The authors attributed this to uncontrolled anaerobic degradation during storage. When estimating COD fractions of domestic wastewater using a respirometer, Matheiu & Etienne (2000) found that readily biodegradable COD values were lower when the wastewater was stored aerobically and recommended storing waste for less than 24 hours at $4^\circ C$ to reduce degradation. Even with efforts to reduce uncontrolled biodegradation on the farm by using fresh waste, Deng et al. (2008) treating swine waste in a 15L 3day HRT UASB, found a denitrification potential of 0.3. They concluded their waste was not suitable for a BNR process because operation of the UASB system favored readily

biodegradable COD conversion to biogas. Therefore, waste storage is not the only contributing factor to bioavailability of waste for a BNR system.

AD is useful as a pre-treatment to transform carbon in the waste into VFAs (S_S) that can easily be absorbed by microorganisms during denitrification. During AD of synthetic wastewater, De Lucas et al., (2000) found that with increasing HRT from 1.25 hours to 24 hours, readily biodegradable COD fraction in the effluent increased from approximately 15% to 55% respectively. This was because, with increasing SRT, the microorganisms had more time to degrade the waste and hydrolyse slowly biodegradable COD to readily biodegradable COD. Kuo et al., (1996), also using synthetic wastewater, found that with increasing SRT, more readily biodegradable COD was produced in form of VFAs, and readily biodegradable SMPs. Nevertheless, increasing readily biodegradable COD concentration does not necessarily mean that the denitrifiers, utilize it all to convert NO_3^- to N_2 . A portion of readily biodegradable COD (almost 50%) is stored inside their cells before denitrification occurs (Boursier et al., 2005; Magrí & Flotats, 2008). Denitrifiers store S_S in their cells as part of their biosynthesis activity and use it for energy when there is no external carbon source available (Ra et al., 2000).

Although there has been some work on the denitrification potential of anaerobically digested swine wastes, there is very limited literature that explicitly covers the effect of SRT readily biodegradable COD concentration when treating swine waste. Therefore, the main objective of this study is to investigate how operation of AD at different SRTs affects S_S and NH_4^+ -N concentrations, and denitrification potential of the internal carbon source for a BNR system.

CHAPTER 3: MATERIALS AND METHODS

Three bench-scale AD reactors were operated under similar OLR and varying SRT depending on study phase. Section 3.1 explains the farm operations where the swine waste was collected, section 3.2 describes the bench-scale AD reactors, and section 3.3 presents the analytical methods.

3.1 Farmer Lyons and His Operation

Swine waste was collected from a show hog farm in Mayo FL. The Lyons' family operates Lyons' Show Pig Company where >6 month old pigs are show-cased to potential buyers. Pigs are chosen based on weight and look. To ensure pigs are well fed, the Lyons' family uses Sunglo/Akey feeds (Quitman, GA). To ensure the pig barns are clean, the floor is slated for feces and urine to drain into a storage tank. The wastewater from the tank is then pumped weekly into an AL. The effluent from the AL is pumped into a hay and rye farm nearby. Only the feces portion of the swine wastewater was used for the AD reactors due to the collection system on the farm. In addition, due to distance between the farm and laboratory, swine waste used in the experiments was stored in a -20°C freezer for periods of up to 9 months.

3.2 Reactor Design and Operation

The study was operated in two phases. Operating conditions and duration of each phase are illustrated on Table 3.1. The reactors were fed three times per week (semi-continuous mode).

Table 3.1: Summary of study operation

Phase	Weeks	OLR (kg VS/ m ³ -day)	SRT (days)			Description
			R1	R2	R3	
I	16	1.88 ± 0.2	28	28	28	Start-up
II	12	1.88 ± 0.2	14	21	28	SRT study

3.2.1 Phase I: Start Up

Initially the reactors were inoculated with sludge from an anaerobic digester treating food waste in Dr. Ann Wilkie's laboratory at the University of Florida in Gainesville, FL. All three reactors were operated at the same SRT (28 days) and volume (1.5 L). They were managed in semi-continuous mode, continuously mixed and incubated at 35°C in a Gyromax 727 orbital shaker incubator (Lafayette, CA). pH was maintained between 7.0-7.7 by addition of 3.0 N NaOH as needed. Reactor feed was prepared by blending 0.26 kg of frozen swine waste with 1.20 L of groundwater to yield a mean VS concentration of 51 g/L and OLR of 1.88 ± 0.2 kg VS/ m³-day. Parameters monitored included influent and effluent pH, TS, VS, COD, TN, TP, VFA, alkalinity, and NH₄⁺-N. Biogas was collected in 10.0 L flexfoil gas bags from SKC Inc. (Eighty four, PA). Volume of bags was determined using water displacement and biogas was emptied twice a week. CH₄ content was measured using a gas chromatograph (Gow Mac instrument CO. Bethlehem, PA).

3.2.2 Phase II: SRT Study

During phase II, the reactors' SRT were switched to 14 days, 21 days and 28 days. However, the OLR was maintained at 1.88 ± 0.2 kg VS/ m³-day (Table 3.1). This change brought variability and complexity to the operation. Each reactor received a

different feed. In addition, to make the influent more representative of wastewater found on a farm, the feed was spiked with urea to increase $\text{NH}_4^+\text{-N}$ concentration for the first 3 weeks of phase II. However, TAN inhibition was noticed and the urea dose in the feed was reduced from 2.27 g N/L to 0.67 g N/L after week 3 of phase II. This will be discussed further in the results and discussion sections of this thesis. pH was maintained between 7.0 and 7.7 by addition of 3.0 N NaOH as needed. Parameters monitored included influent and effluent pH, TS, VS, COD, TN, TP, VFA, alkalinity, $\text{NH}_4^+\text{-N}$ concentrations, biogas volume, CH_4 content, and effluent S_5 portion.

3.3 Analysis Methods

This section provides a brief description of the methods used to monitor AD reactor performance and the techniques used to measure effluent S_5 portion. More detail on the analytical methods is provided in Appendix A. pH was monitored three times per week; all other parameters were analyzed weekly. Apart from TS and VS, analysis were performed on centrate obtained by centrifuging influent and effluent samples in a Thermo scientific CL2 centrifuge (West Palm Beach, FL) for 10 minutes at 3500 rpm. For accuracy, triplicate samples were performed for each reactor and feed for TN, TP, COD, VFA, CH_4 content, and S_5 analysis.

Standard methods were used to measure TN (4500- NO_3^- E and 4500-P E), TP (4500-P J), COD (5200 B), alkalinity (2320 B), CH_4 content (6211 C), VS, and TS (2540 G) (APHA et al., 2012). The $\text{NH}_4^+\text{-N}$ testing method was adapted from Willis et al. (1996), with modification of color reagent storage time. VFA concentrations were measured using the method described by Montgomery et al. (1962), with modification of spectrophotometer wavelength. Biogas volume was measured using wet tip gas meters

from Wayne, PA. Method detection limits (MDL) for the methods were measured to be 0.7 mg N/L for TN, 0.04 mg P/L for TP, 30 mg COD/L for COD, 0.7 mg N/L for NH_4^+ -N, and 14 mg COD/L for VFA.

3.3.1 Respirometry

The respirometric assessment of readily biodegradable COD concentration in the AD centrate was performed using a pulse flow (PF-8000) respirometer system from Respirometer Systems and Applications (RSA) LLC (Springdale, AK). The OUR test procedure for this study was similar to the one described by Young & Cowan (2004). The laboratory set up (Figure 3.1) consisted of 0.2 L test vessels operated in batch mode. Data were collected from a blank and triplicate test vessels for each reactor's centrate. The vessels were placed in a 25°C water bath and DMS stirring base, continuously mixed at 450 rpm for 20-24 hours. A shot (0.01 g) of nitrification inhibitor, Formula 2533 (Hach company, Loveland, CO), was added to the vessels to prevent interference from nitrification. Each reactor also had an absorbance cup with 5.0 mL of 6.0 N potassium hydroxide (KOH) to absorb CO_2 because the presence of CO_2 could lead to misinterpretation of data. Test vessels were aerated constantly with O_2 to ensure DO concentration was between 6.0 and 8.0 mg/L. Each vessel received centrate (carbon source) obtained from centrifuging slurry from each reactor and seeded with biomass with a mixed liquor volatile suspended solid (MLVSS) concentration of 3.0 ± 0.5 g VSS/L to start with a F/M ratio of 0.67 mg centrate COD/mg biomass VSS. Biomass was obtained from the aeration tank in the MLE process at Southwest Hillsborough County Wastewater Treatment Facility in Tampa FL. Appropriate nutrients and buffer solutions were added to the vessels. After 20-24 hours of testing, an OUR profile was

developed and the readily biodegradable COD concentrations were calculated in accordance to the model presented by Young (2012).

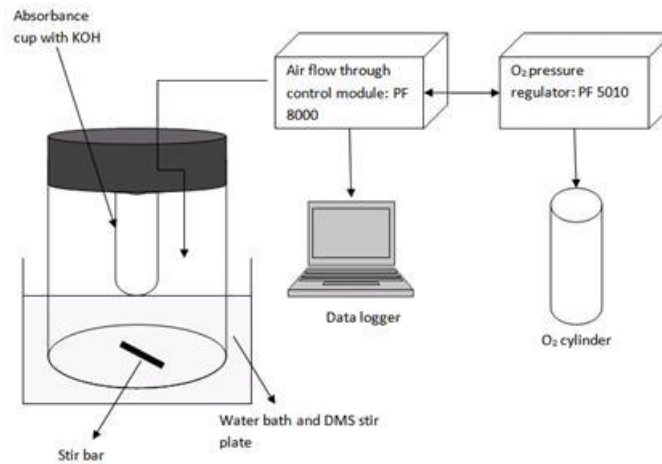

Figure 3.1: Respirometer test set-up

3.3.2 Nitrate Removal

NO_3^- removal was analyzed using a microcosm study. A NO_3^- -N stock solution was prepared using KNO_3 as described in Standard Method 4500- NO_3^- -B (APHA et al., 2012). With known centrate soluble COD and biomass MLVSS concentration, an F/M ratio of 0.67 mg centrate COD/mg biomass VSS was used for each 100 mL test vessel. Replicate test vessels were used for each reactor. Biomass was obtained from the anoxic tank in the MLE process at Southwest Hillsborough County Wastewater Treatment Facility in Tampa, FL. Each vessel was spiked with 1 g NO_3^- -N/L at the beginning of the test. The test vessels were then placed on a VWR OS-500 shaker table for 18 hours. Influent and effluent NO_3^- -N concentrations were measured using Metrohm 863 compact autosampler and 881 compact IC pro (Riverview, FL).

CHAPTER 4: DATA ANALYSIS

This chapter provides information on the statistical tools and models that were used in this research, including: (1) mass balance data for COD and nutrients, (2) statistical analysis of the results and (3) concentration of the readily biodegradable COD in the centrate from the reactors from respirometric data.

4.1 Mass Balances

4.1.1 COD Mass Balance Calculations

The steady state anaerobic digestion model 1 (ADM1) described by Batstone et al., (2002) and Söttemann et al. (2005a) was used to perform the COD mass balance analysis for this study. Because hydrolysis is the common rate-limiting step during AD, the model follows Monod hydrolysis kinetics to quickly and reasonably estimate process performance (Batstone et al., 2002). COD fractions were divided into particulate and soluble fractions, as illustrated on Figure 4.1. The unbiodegradable particulate COD fraction ($f_{PS,up}$), acidogen yield coefficient (Y_{AD}) and acidogen endogenous respiration rate (b_{AD}) were obtained from the literature (Table 4.1), because this research did not do any kinetics studies. The values were obtained from a kinetic study of AD of swine waste at 37°C (Massé & Droste, 1999). The acidogen yield coefficient and acidogen endogenous respiration rate were used for this model because of all the microorganisms in the AD process, acidogens have the highest yield coefficient, which influences the

biomass growth in the digester and affects effluent COD concentrations and CH₄ yield (Söttemann et al., 2005b).

Table 4.1: Kinetic parameters for AD of swine waste used in steady state Monod hydrolysis kinetics COD mass balance (Massé & Droste, 1999)

Parameter	Value
Unbiodegradable particulate COD fraction ($f_{PS'up}$)	0.25
Acidogen yield coefficient (Y_{AD}) mg VS COD/mg carb.COD	0.228
Acidogen endogenous respiration rate (b_{AD}) day ⁻¹	0.006

Total influent COD (C_T) is comprised of unbiodegradable (C_I) and biodegradable (C_S) COD fractions. To calculate the unbiodegradable COD fraction in the influent, first the total influent particulate COD (X_{tim}) was calculated by assuming a molecular formula for the swine waste of C₆H₁₃O₅N (Choi, 2007). The COD equivalent was calculated using Eq. 4.1 and X_{tim} was calculated using Eq. 4.2. With X_{tim} calculated, the particulate biodegradable (X_S) and particulate unbiodegradable (C_I) portions were calculated using Eq. 4.3 and 4.4, respectively. The non-VFA fraction of the total influent biodegradable COD (C_S) concentration undergoes the same hydrolysis process as the biodegradable particulate COD (X_S) and so was included as part of X_S .

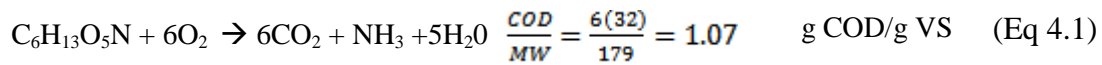

$$X_{tim} = O_2 \text{ equivalents} \times \text{VS concentration (g/L)} \quad \text{g COD/L} \quad (\text{Eq 4.2})$$

$$X_S = (1 - f_{PS'up}) X_{tim} - S_{bai} \quad \text{g COD/L} \quad (\text{Eq 4.3})$$

where S_{bai} = influent VFA concentration (g COD/L)

$$C_I = f_{PS'up} X_{tim} \quad \text{g COD/L} \quad (\text{Eq 4.4})$$

The unbiodegradable soluble COD (S_I) in steady state AD systems are small compared to the total influent unbiodegradable COD (C_I) and assumed to be zero (Sotemann et al., 2005a).

COD is lost in the AD process through bioprocesses as the acidogens grow through hydrolysis to produce acidogen biomass (Z_{AD}). COD is ‘gained’ when the acidogens die off. A general mass balance equation (Eq 4.5) is used for each of the COD fractions; residual biodegradable (S_{bp}), unbiodegradable soluble (S_I), acidogen biomass and methane (S_m) as shown in Figure 4.1.

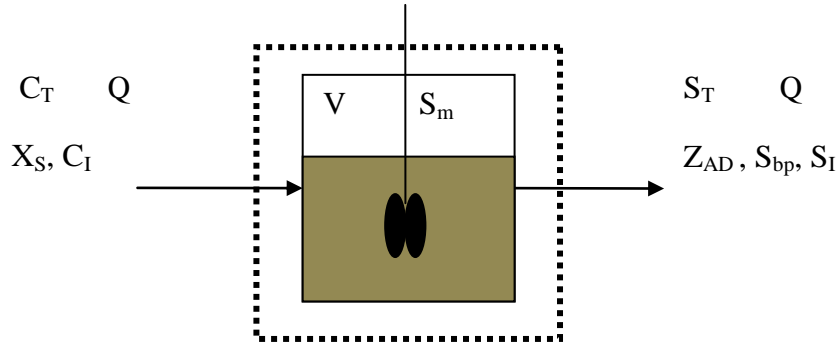

Figure 4.1: COD flow through steady state AD process model

For a flow of Q through the system, the mass balance for total effluent residual biodegradable COD is shown in Eq 4.6.

$$[\text{Change in mass}] = [\text{Mass in}] - [\text{Mass out}] - [\text{Mass lost through bioprocesses}] + [\text{Mass gained through bioprocesses}] \quad (\text{Eq 4.5})$$

$$\frac{dS_{bp}}{dt} V = QX_S - QS_{bp} - \mu V + b_{AD}Z_{AD}V$$

where μ = hydrolysis rate (g COD/L-d) (Eq 4.6)

V = volume (L)

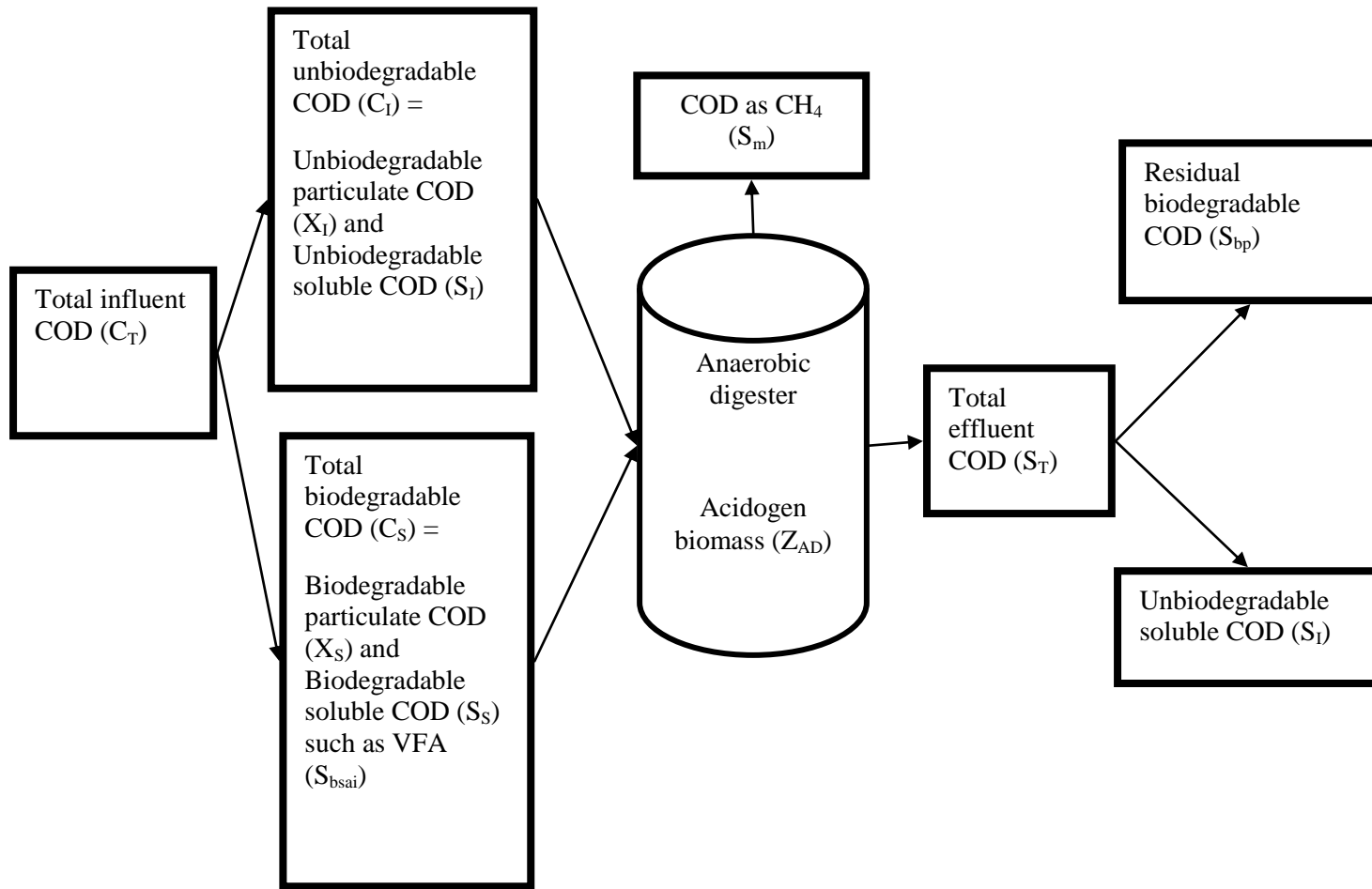

Figure 4.2: Conceptual model for COD mass balance

Eq 4.6 was then divided by V yield:

$$\frac{dS_{bp}}{dt} = \frac{X_s - S_{bp}}{SRT} - \mu + b_{AD}Z_{AD} \quad (\text{Eq 4.7})$$

The same concept used to derive residual biodegradable COD concentration can be used for acidogen biomass concentration to yield:

$$\frac{dZ_{AD}}{dt}V = 0 - QZ_{AD} + Y_{AD}\mu V - b_{AD}Z_{AD}V \quad (\text{Eq 4.8})$$

In this equation the influent acidogen biomass was assumed to be zero. Dividing Eq 4.8 by V yields:

$$\frac{dZ_{AD}}{dt} = -\frac{Z_{AD}}{SRT} + Y_{AD}\mu - b_{AD}Z_{AD} \quad (\text{Eq 4.9})$$

Since the model used assumed that the AD process was at steady state, Eq 4.7 and 4.9 equal zero. With this assumption, two hydrolysis rate equations were derived:

$$\mu = \frac{X_s - S_{bp}}{SRT} + b_{AD}Z_{AD} \quad \text{g COD/L.d} \quad (\text{Eq 4.10})$$

$$\mu = \frac{Z_{AD}}{Y_{AD}} \left(\frac{1}{SRT} + b_{AD} \right) \quad \text{g COD/L.d} \quad (\text{Eq 4.11})$$

Equations 4.10 and 4.11 were set equal to each other to calculate Z_{AD} :

$$Z_{AD} = \frac{Y_{AD}(X_s - S_{bp})}{[1 + b_{AD}SRT(1 - Y_{AD})]} \quad \text{g COD/L} \quad (\text{Eq 4.12})$$

The hydrolysis rate is assumed to follow Monod kinetics (Eq 4.13):

$$\mu = \frac{\mu_{max}S_{bp}}{K_s + S_{bp}} Z_{AD} \quad \text{g COD/L.d} \quad (\text{Eq 4.13})$$

where μ_{max} = Maximum hydrolysis rate

K_s = Half saturation coefficient

Equation 4.13 was substituted into Eq 4.11 to solve for the concentration of residual biodegradable COD:

$$S_{bp} = \frac{K_s \left(\frac{1}{SRT} + b_{AD} \right)}{Y_{AD}\mu_{max} - \left(\frac{1}{SRT} + b_{AD} \right)} \quad \text{g COD/L} \quad (\text{Eq 4.14})$$

It was assumed that the unbiodegradable fraction of dead acidogens was negligible and therefore did not contribute to the unbiodegradable fraction of COD (Eq 4.15).

$$C_I = S_I \quad \text{g COD/L} \quad (\text{Eq 4.15})$$

The same flow rate and yield coefficient were used to calculate effluent CH₄ concentration (S_m). S_m production of CH₄ is directly affected by the rate at which biodegradable influents hydrolyze. To simplify the mathematics, the effluent methane concentration, S_m, was calculated as if all of the methane was dissolved in the liquid. Therefore S_m, in terms of COD was derived using the rate of hydrolysis.

$$\frac{dS_m}{dt}V = 0 - QS_m + (1 - Y_{AD})\mu V \quad (\text{Eq 4.16})$$

$$S_m = (1 - Y_{AD})SRT\mu \quad \text{g COD/L} \quad (\text{Eq 4.17})$$

Lastly the overall mass balance for system shown in Figure 4.1 was derived:

$$X_{\text{tic}} = S_{\text{bp}} + Z_{\text{AD}} + S_I + S_m \quad \text{g COD/L} \quad (\text{Eq 4.18})$$

where X_{tic} = Calculated total influent particulate COD from ADM1

$$\text{COD balance} = 100 \left(\frac{X_{\text{tic}}}{X_{\text{tim}}} \right) \quad \%$$

where X_{tim} = Measured total influent particulate COD (Eq 4.2)

$$(\text{Eq 4.19})$$

4.1.2 Nitrogen Mass Balance Calculations

The nitrogen (N) mass balance was performed using an input output model for a CSTR. This model is based on the total nitrogen and an assumed molecular formula for the influent and effluent VS. Total influent N (C_T) into the system is comprised of solid (C_{TIS}) and liquid (C_{TIL}) N fractions (Figure 4.3). The liquid influent N fraction (C_{TIL}) was determined from experimental data. The molecular formula for the swine waste was assumed to be C₆H₁₃O₅N (Choi, 2007). The fraction of N (F_{NI}) in the solids was calculated from the molecular formula (Eq 4.20) and the C_{TIS} was calculated using Eq 4.21:

$$C_6H_{13}O_5N \quad F_{NI} = \frac{N}{MW} = \frac{14}{179} = 0.078 \quad \text{g N/g influent VSS} \quad (\text{Eq 4.20})$$

$$C_{TIS} = F_{NI} \times \text{VS influent concentration (g/L)} \quad \text{g N/L} \quad (\text{Eq 4.21})$$

The molecular formula for the AD effluent was assumed to be $C_5H_7O_5N$ (Choi, 2007). The fraction of N (F_{NE}) in the solids was calculated from the molecular formula (Eq 4.22) and the C_{TES} was calculated using Eq 4.23. Liquid effluent N fraction (C_{TEL}) was determined from experimental data.

$$C_5H_7O_5N \quad F_{NE} = \frac{N}{MW} = \frac{14}{113} = 0.124 \quad \text{g N/g effluent VSS} \quad (\text{Eq 4.22})$$

$$C_{TES} = F_{NE} \times \text{VS effluent concentration (g/L)} \quad \text{g N/L} \quad (\text{Eq 4.23})$$

A general mass balance for the N was used (Eq 4.24). For a flow of Q through the system (Figure 4.4), the mass balance for total effluent N for a time dt is shown in Eq 4.25.

$$[\text{Change in N mass}] = [\text{N mass in}] - [\text{N mass out}] - [\text{N mass lost}] + [\text{N mass gained}] \quad (\text{Eq 4.24})$$

$$\frac{dC_{TE}}{dt} V = QC_{TI} - QC_{TE} - r_{loss}V + r_{gain}V \quad (\text{Eq 4.25})$$

It was assumed that there was no N mass gained in the AD reactors. Potential N mass loss mechanisms in the AD reactors were assumed to be from struvite precipitation and/or volatilization of the gaseous FA (F_g) when the reactors were opened during feeding. NH_3 and NH_4^+ concentrations depend on pH and as pH increases gaseous FA concentrations increase (Strik et al., 2006). During this study, pH levels were about neutral; due to this volatilization of gaseous FA was not assumed to be negligible. Dividing Eq 4.25 by V yielded Eq 4.26. However, because steady state was assumed, Eq 4.26 was assumed to equal to zero to yield Eq 4.27:

$$\frac{dC_{TE}}{dt} = \frac{C_{TI} - C_{TE}}{SRT} \quad (\text{Eq 4.26})$$

$$C_{TI} = C_{TE} \quad \text{g N/L}$$

where $C_{TI} = C_{TIL} + C_{TIS}$ (Eq 4.27)

$$C_{TE} = C_{TEL} + C_{TES}$$

$$\text{N balance} = 100 \times \left(\frac{C_{TE}}{C_{TI}} \right) \quad \% \quad (\text{Eq 4.28})$$

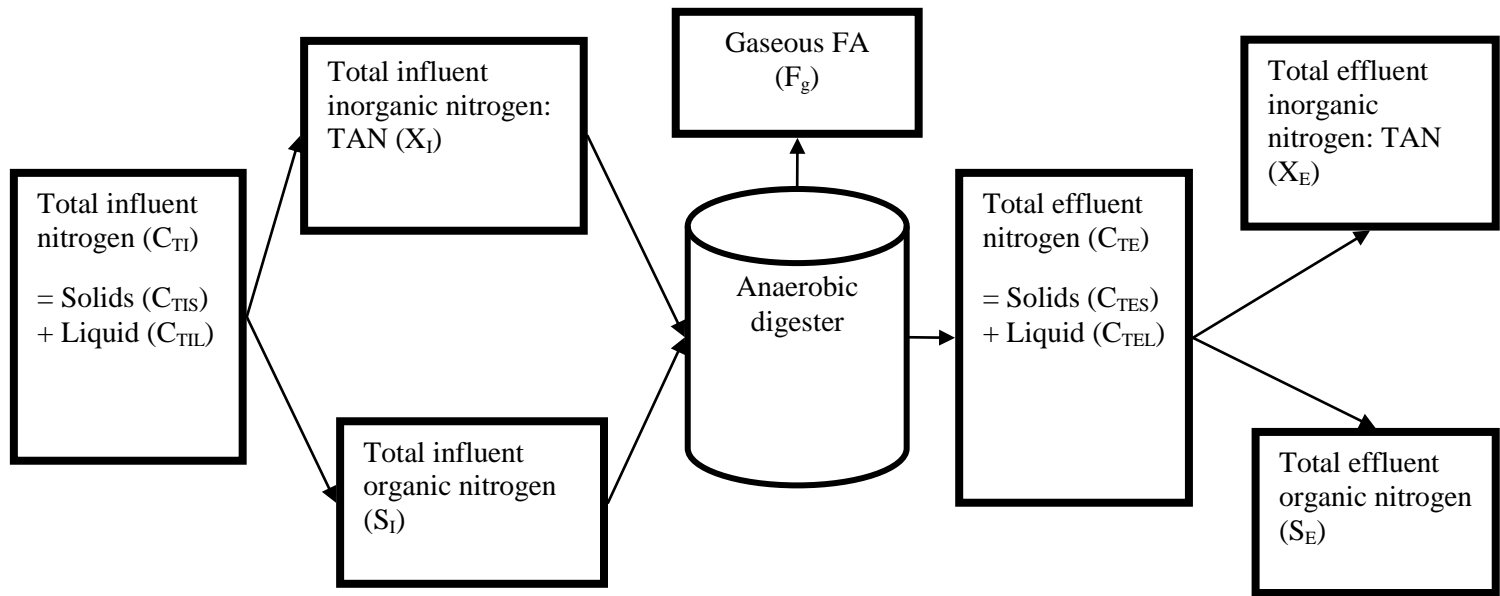

Figure 4.3: Conceptual model for nitrogen mass balance

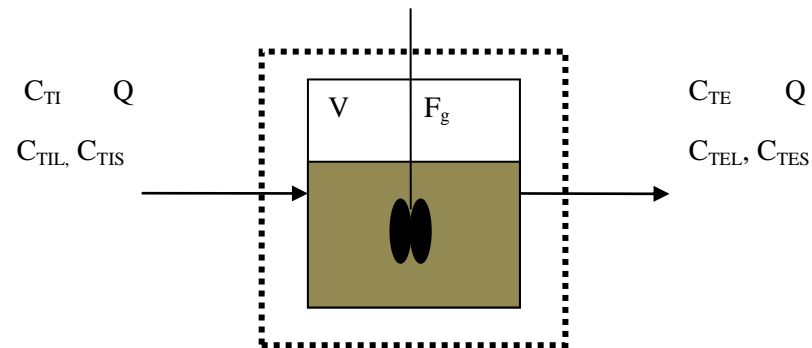

Figure 4.4: Nitrogen flow through steady state AD process model

4.1.3 Phosphorus Mass Balance Calculations

Due to ions present in the swine waste (Mg^{2+} , Ca^{2+} and K^+), precipitation of metal phosphates occurs when the phosphorus present in the organic waste is released to form metal phosphates precipitates from solutions in the AD reactors (Marti et al., 2008). A general mass balance for P was used (Eq 4.29). For the flow of Q through the system (Figure 4.6), the mass balance for the total effluent P for a time dt is shown in Eq 4.30.

$$[\text{Change in P mass}] = [\text{P mass in}] - [\text{P mass out}] - [\text{P mass lost}] + [\text{P mass gained}] \quad (\text{Eq 4.29})$$

$$\frac{dP_{TE}}{dt} V = QP_{TI} - QP_{TE} - r_{loss}V + r_{gain}V \quad (\text{Eq 4.30})$$

The fraction of P (F_{PI}) in the influent solids was assumed to be 2.1% of the total solids concentration (Szögi et al., 2006). P_{TIS} was calculated using Eq 4.31:

$$C_{TIS} = F_{PI} \times \text{TS influent concentration (g/L)} \quad \text{g P/L} \quad (\text{Eq 4.31})$$

The molecular formula for the AD effluent was assumed to be $C_5H_7O_5N$ (Choi, 2007). The fraction of P (F_{PE}) in the effluent solids was assumed to be a fifth of the N fraction calculated from the molecular formula (Eq 4.22) and the P_{TES} was calculated using Eq 4.33 (Carlos et al., 1998). Liquid effluent P fraction (P_{TEL}) was determined from experimental data.

$$F_{PE} = \frac{F_{NE}}{5} = \frac{0.124}{5} = 0.025 \quad \text{g P/g effluent TS} \quad (\text{Eq 4.32})$$

$$P_{TES} = F_{PE} \times \text{TS effluent concentration (g/L)} \quad \text{g P/L} \quad (\text{Eq 4.33})$$

To determine if there was a P loss or gain mechanism in the AD reactor, the thermodynamic solubility product of $[Mg^{2+}] [NH_4^+] [PO_4^{3-}]$ was used as an example to

determine if there were any metal precipitates. $[Mg^{2+}] [NH_4^+] [PO_4^{3-}]$ solubility product was greater than struvite solubility product 12.6 at 35°C: therefore, it was assumed that struvite and possibly other metal precipitates were precipitating from the solution Loewenthal et al. (1995). Magnesium concentrations were determined from experimental data from a BNR study of the centrate from this research. It was assumed that the reactors were at steady state therefore Eq 4.34 was equal to zero. Since specific concentrations of metal precipitates were not measured, rates of loss and/or gain were not included in mass balance calculations (Eq 4.35). An assumption was made that P balance (Eq 4.36) less than 100% was due to metal precipitates.

$$\frac{dP_{TE}}{dt} = \frac{P_{TI} - P_{TE}}{SRT} - r_{loss} + r_{gain} \quad (\text{Eq 4.34})$$

$$P_{TI} = P_{TE} \quad \text{g P/L}$$

where $P_{TI} = P_{TIL} + P_{TIS}$ (Eq 4.35)

$$P_{TE} = P_{TEL} + P_{TES}$$

$$\text{P balance} = 100 \times \left(\frac{P_{TE}}{P_{TI}} \right) \quad \% \quad (\text{Eq 4.36})$$

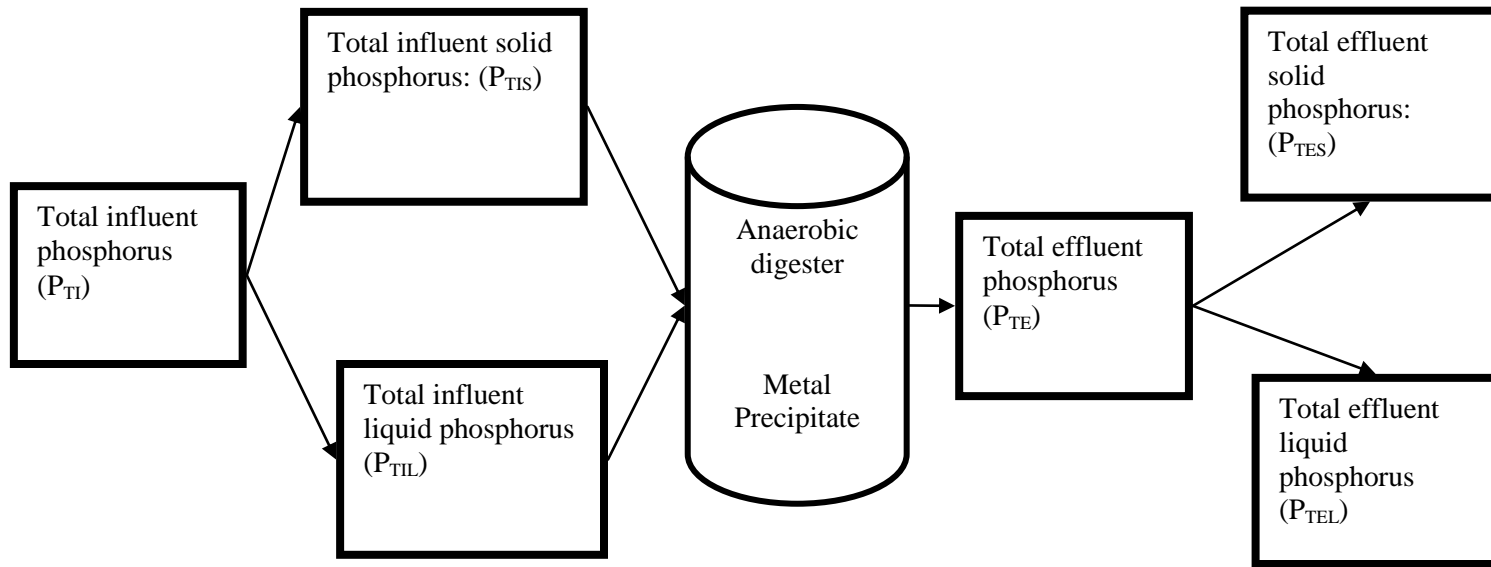

Figure 4.5: Conceptual model for phosphorus mass balance

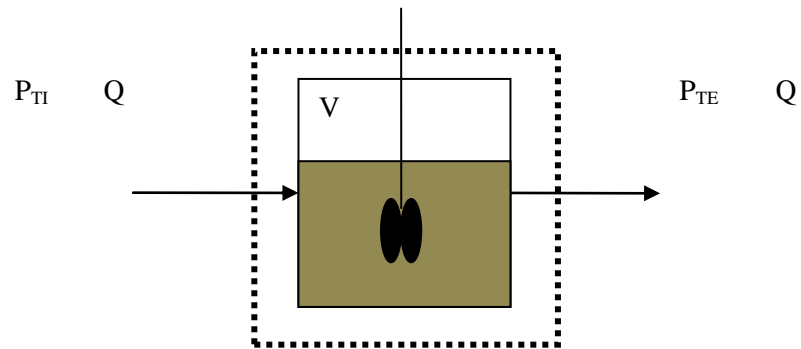

Figure 4.6: Phosphorus flow through AD process

4.2 Statistical Significance

Statistical analysis was performed using one-way analysis of variance (ANOVA) with Tukey-Kramer Multiple Comparisons test using GraphPad InStat version 3.10 for Windows XP (GraphPad Software, San Diego California USA, www.graphpad.com). P values less than 0.05 were considered statistically significant and values less than 0.0001 were considered extremely significant. Analyses were performed at a 95% confidence level.

4.3 Respirometry Analysis

The general kinetic model was used to calculate readily biodegradable COD concentrations from raw respirometer data. The Excel spreadsheet model was received through personal communications with James C. Young (Young, 2012). The model worked by inputting raw respirometer oxygen uptake (OU) data to calculate measured OUR (Eq 4.37). Measured OU and OUR versus time graphs were then plotted.

$$\text{Measured OUR} = \frac{\text{OU (mgO}_2\text{/L)}}{\text{Time (hr)}} \quad \text{mg O}_2\text{/L-hr} \quad (\text{Eq 4.37})$$

Next, model parameters were inputted into the model to calculate OU and OUR. The model parameters were dependent on waste characteristics. Table 4.3 shows these model parameters and a brief comment on why the specific numbers were chosen. Once these parameters were inputted into the spreadsheet, the calculated OU and OUR versus time graphs were plotted. Readily biodegradable COD concentrations were estimated by curve fitting, the measured OU to calculated OU and the measured OUR to calculated OUR graphs. To optimize the fit, yield coefficient, decay rate, intrinsic half saturation

coefficient and initial total biomass were adjusted to calculate the readily biodegradable COD concentration.

Table 4.2: Kinetic and biological parameters inputted into Young's general kinetic model software to calculate calculated OU and OUR

Parameter	Symbol	Unit	Value	Comment
Yield Coefficient	Y	<i>mg VSS/mg COD removed</i>	0.50	This was used as the yield coefficient for aerobic heterotrophs (Young, 2012)
Inhibition factor	k^*		1	$k^*= 1$ if no toxins were present
Intrinsic half saturation coefficient	K_s	<i>mg COD/L</i>	100	Because the K_s value for the biomass was not know, starting at 100 mg COD/L was recommended (Young, 2012)
Inhibition factor	K_s^*		1	$K_s^*= 1$ if no toxins existed in biomass
Haldane inhibition factor	K_i		10000	Haldane inhibition comes from the presence of phenol in the centrate. $K_i = 10,000$ if no phenol existed in the centrate (Sudain et al., 1988)
Decay rate	b	<i>mg VSS/mg VSS/d</i>	0.01-0.12	Started with known swine waste decay rate (Massé & Droste, 1999) and was adjusted appropriately for the aerobic heterotrophs decay rate
mg COD/mg VSS		<i>mg COD/mg VSS/hr</i>	1.42	Assumption that the MLVSS and the centrate had a molecular formula of $C_5H_7O_2N$
Biomass activity factor	f		0.8	Used 0.80 unless value was known (Young, 2012)
Soluble microbial products	SMP	<i>mg SMP COD/mg COD</i>	0.60-0.90	Depended on weekly soluble COD concentration for each AD reactor
Initial total biomass		<i>mg VSS/L</i>	150-3000	Began with known MLVSS value of 3000 mg VSS/L
Time interval		<i>hour</i>	0.17	Time interval that was used to measure OU data during the respirometer test

CHAPTER 5: RESULTS

This section will present the results from phases I and II including removal efficiencies, bioavailability of organic C for denitrification, biogas production, methane yield, and COD and nutrient mass balances.

5.1 Phase I: Start Up

Average influent and effluent concentrations and removal efficiencies for solids, COD and VFAs for the three reactors during phase I are shown in Table 5.2. Summary performance data is shown in Table 5.1. Average values are represented because all three reactors' were operated under the same conditions. The average influent TS and VS values are similar to values reported by Kaparaju & Rintala (2005), who also treated swine waste at 35°C in a CSTR. However, removal efficiencies for TS and VS were higher in this study, compared to other reported studies, shown in Table 2.2 (Astrals et al., 2012; Kaparaju & Rintala, 2005; Ndegwa et al., 2005; Sanchez et al., 1995). The average CH₄ content in the produced biogas was 67.0% by volume. The mean CH₄ yield, over the 23 weeks of operation, of 0.43 m³CH₄/kg VS added was higher than achieved by Burton and Turner (2003), who observed a typical CH₄ yield of 0.30 m³CH₄/kg VS added. High COD and VS removal rates were attributed to the low influent concentrations of VFA and the biodegradability of the waste, possibly due to freezing of the waste, as discussed in chapter 6 of this thesis. The high organic matter (VS) destruction led to higher CH₄ yields. The average TAN concentration was below the

inhibitory range for AD (Gerardi, 2003). This low TAN concentration also led to the good reactor performance observed in this study (Amani 2010, Burton & Turner, 2003, Sakar et al., 2009).

Table 5.1: Phase I average performance data results for swine waste from three 1.5 L reactors operated at an OLR of 1.88 kg VS/m³-d and SRT of 28 days for 16 weeks

Parameter	Unit	Results
CH₄ production	<i>m³CH₄/m³reactor-day</i>	0.77± 0.4
Gas composition	% CH ₄	67.0 ± 2.7
CH₄ yield	<i>m³CH₄/kg VS added</i>	0.43 ± 0.2
Percent Reduction		
TS	%	58.3 ± 3.8
VS	%	69.8 ± 2.5
Soluble COD	%	62.8 ± 2.6
Total COD	%	60.0 ± 8.3
VFA	%	76.8 ± 1.8

Table 5.2: Phase I average summary results for swine waste influent and effluent three 1.5 L reactors operated at an OLR of 1.88 kg VS/m³-d and SRT of 28 days for 16 weeks

Parameter	Unit	Results	
		Influent	Effluent
TS	<i>g/L</i>	69.0 ± 1.9	28.8 ± 1.4
VS	<i>g/L</i>	51.0 ± 1.5	15.4 ± 0.8
Alkalinity	<i>g CaCO₃/L</i>	6.36 ± 6.4	12.0 ± 4.5
TAN	<i>g NH₄⁺-N/L</i>	0.27 ± 0.2	0.64 ± 0.3
Soluble TN	<i>g N/L</i>	0.46 ± 0.4	0.63 ± 0.5
Total Nitrogen*	<i>g N/L</i>	4.40 ± 0.9	2.80 ± 0.5
Soluble TP	<i>mg P/L</i>	131 ± 22	126 ± 50
Soluble COD	<i>g COD/L</i>	13.5 ± 2.8	5.01 ± 13
Total COD*	<i>g COD/L</i>	79.0 ± 29	31.6 ± 4.2
VFA	<i>g COD/L</i>	2.85 ± 1.2	0.66 ± 0.7
pH		7.70 ± 0.0	7.30 ± 0.0
* Calculated values: Total nitrogen = Eq 4.21 and Eq 4.23 Total COD = COD fraction in solids (VS) + soluble COD			

5.2 Phase II: SRT Study

5.2.1 Overall Performance and Summary

Average performance for the three reactors operating at different SRTs and the same OLR is shown in Table 5.3. A summary of performance data for the three reactors is shown in Table 5.4. Steady state operating conditions were never reached for any of the reactors during the 12 weeks of operation. This may have been caused by the addition of urea into the influent during Phase II. Addition of urea may have disrupted the microorganisms by increasing TAN concentrations. During the first three weeks of Phase II, 2.27 g N/L was added to the feed to mimic swine waste found on farms. During this three week period, TAN concentrations were above the typical range (1.24-1.70 g NH₄⁺-N/L) (Choi, 2007; Nuchdang & Phalakornkule, 2012) and biogas production and pH decreased (Figures 5.1B and C); therefore, the concentration of urea added to the feed was reduced to 0.67 g N/L. Although biogas production decreased and TAN concentrations increased (Figure 5.2A), CH₄ yield was not greatly affected because the FA concentrations (Figure 5.2B) were below inhibitory range for FA on methanogens of 0.7-1.1g N/L (Angelidaki & Ahring, 1993; Hansen et al., 1998). Just as in Phase I, the overall good performance was observed during Phase II. This was attributed to freezing the manure and low TAN and FA concentrations, as described previously.

The reactor with the 21 day SRT had the highest CH₄ yield; however, differences in CH₄ yield were not statistically significant. The 14 day SRT reactor had the highest % CH₄ content in the biogas, lowest VFA concentration and consistently had the highest VS removal (Figure 5.1C). Differences in % VS removal, CH₄ yield and content and % VFA removal were significantly different between the reactors (Table 5.3). From this

experiment, it was observed that there is a comprehensible relationship between % VS removal, CH₄ yield, biogas production and SRT as illustrated in Figures 5.1 A, B and C.

VFA concentrations for all three reactors were higher than values (0.1-0.4 g COD/L) previously reported to be inhibitory (Marti et al., 2008; Ndegwa et al., 2005). Even with high VFA concentrations in this experiment, biogas production and CH₄ yield continued because there was enough alkalinity to provide buffering capacity and the pH did not decrease significantly. pH and alkalinity values during the 12 weeks of operation were within the range favorable to methanogens. The VFA to alkalinity ratio for 28, 21 and 14 day SRT was 0.22, 0.11 and 0.08 respectively. The recommended VFA to alkalinity ratio is 0.10-0.20, with a ratio greater than 0.50 causing complete system failures (Gerardi, 2003).

5.2.2 Mass Balance Results

One of the analysis tools used in this thesis was performing a mass balances for COD and nutrients in the reactors, as described in Chapter 4. Mass balances are important because they assist in validating results and making them more comparable. In addition, mass balances help to ensure the technology developed or proposed in the lab can be transferred to full-scale operation in the field (Batstone et al., 2002).

Table 5.3: Phase II average performance data for three 1.5L reactors' swine waste operated at an OLR of 1.88 kg VS/m³-d and varying SRT for 12 weeks.

Parameter	Units	14 day	21 day	28 day	P value	Significant?
CH₄ production	<i>m³CH₄/m³ reactor-day</i>	0.56 ± 0.1	0.61 ± 0.1	0.55 ± 0.1	0.288	No
Gas composition	<i>% CH₄</i>	76.2 ± 0.5	71.2 ± 2.2	65.1 ± 0.5	0.0002	Yes
CH₄ yield	<i>m³CH₄/kg VS added</i>	0.30 ± 0.0	0.33 ± 0.1	0.28 ± 0.1	0.132	No
Percent Reduction						
TS	<i>%</i>	27.8 ± 0.2	38.0 ± 0.2	41.8 ± 0.2	<0.0001	Yes
VS	<i>%</i>	73.6 ± 3.8	65.2 ± 5.2	58.3 ± 5.6	<0.0001	Yes
Total COD	<i>%</i>	36.8 ± 8.1	43.3 ± 6.3	46.5 ± 6.6	<0.0001	Yes
VFA	<i>%</i>	67.6 ± 5.5	64.4 ± 1.5	37.3 ± 2.5	<0.0001	Yes

Table 5.4: Phase II average summary data for three 1.5 L reactors' swine waste operated at an OLR of 1.88 kg VS/m³-d and varying SRT for 12 weeks.

Parameter	Units	Influent			Effluent		
		14 day	21 day	28 day	14 day	21 day	28 day
TS	<i>g/L</i>	38.5 ± 0.5	57.3 ± 0.7	76.5 ± 0.1	27.8 ± 0.2	35.5 ± 0.4	44.5 ± 0.3
VS	<i>g/L</i>	28.1 ± 0.4	48.1 ± 0.6	56.2 ± 0.7	14.2 ± 0.2	18.1 ± 0.3	23.7 ± 0.6
Alkalinity	<i>g CaCO₃/L</i>	2.34 ± 1.0	3.42 ± 1.5	4.51 ± 2.0	9.07 ± 1.6	10.2 ± 0.8	11.0 ± 2.2
TAN	<i>g NH₄⁺-N/L</i>	0.45 ± 0.3	0.67 ± 0.4	0.89 ± 0.5	0.78 ± 0.3	1.16 ± 0.4	1.55 ± 0.5
Soluble TN	<i>g N/L</i>	0.72 ± 0.1	1.09 ± 0.2	1.46 ± 0.2	1.10 ± 0.4	1.54 ± 0.4	1.92 ± 0.3
Total Nitrogen*	<i>g N/L</i>	3.00 ± 0.2	4.17 ± 0.2	5.57 ± 0.3	2.75 ± 0.2	3.53 ± 0.3	4.77 ± 0.2
Soluble TP	<i>mg P/L</i>	91.2 ± 27	130 ± 41	168 ± 53	48.1 ± 22	64.4 ± 29	91.0 ± 36
Soluble COD	<i>g COD/L</i>	5.97 ± 0.8	8.88 ± 1.2	16.4 ± 6.5	2.78 ± 0.4	4.29 ± 0.4	8.14 ± 2.2
Total COD*	<i>g COD/L</i>	35.1 ± 6.0	52.6 ± 8.9	78.1 ± 15	22.2 ± 3.9	29.8 ± 3.8	41.8 ± 3.5
VFA	<i>g COD/L</i>	2.13 ± 2.2	3.20 ± 0.3	3.86 ± 0.4	0.68 ± 0.1	1.14 ± 0.5	2.42 ± 0.7
pH		7.90 ± 0.0	7.90 ± 0.0	7.90 ± 0.1	6.88 ± 0.2	6.99 ± 0.2	6.90 ± 0.2

* Calculated values: Total nitrogen = Eq 4.21 and Eq 4.23 Total COD = COD fraction in solids (VS) + soluble COD

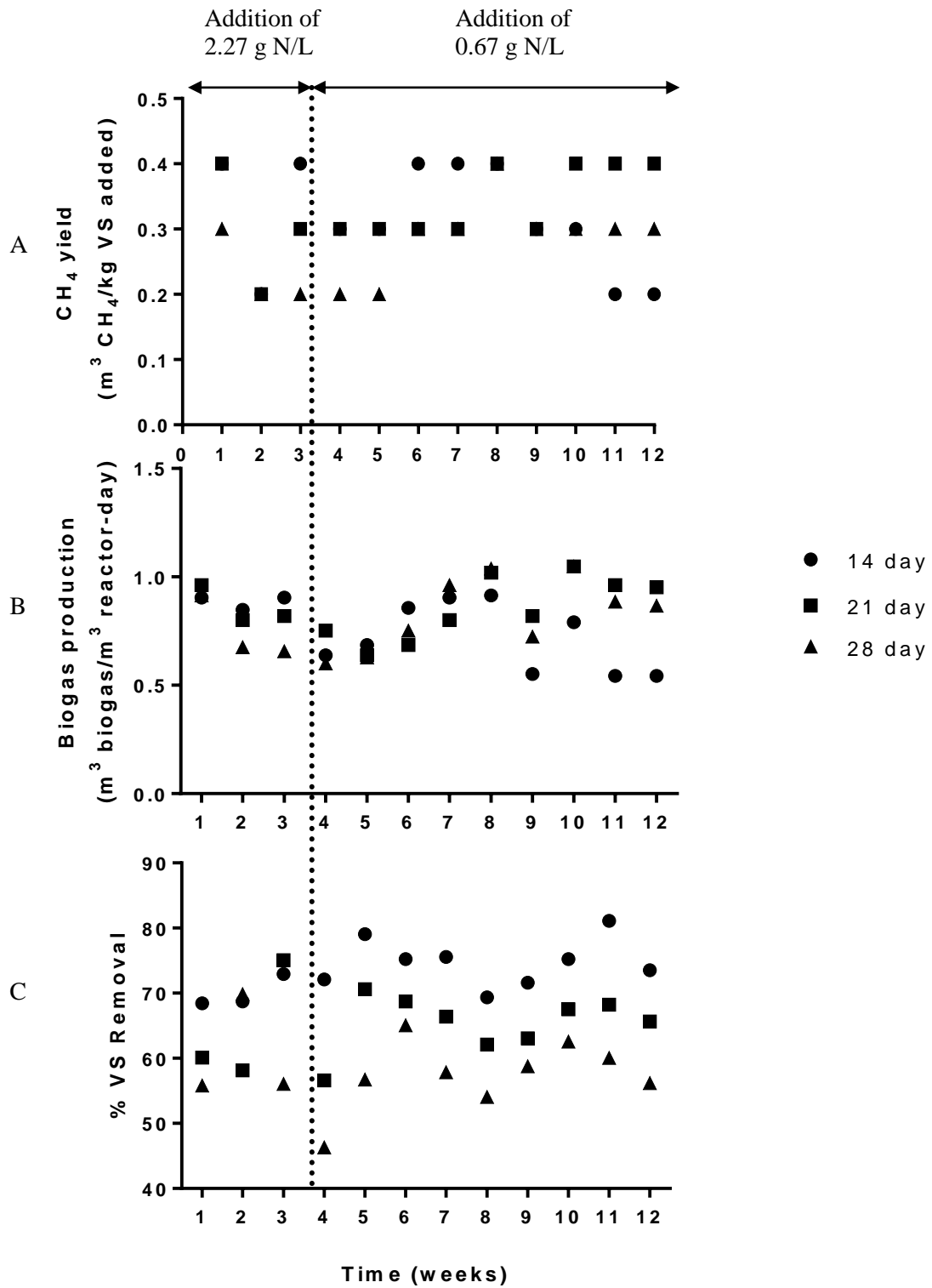

Figure 5.1: Comparison of CH₄ yield (A), biogas production (B) and % VS removal (C) during Phase II for three reactors operating at varying SRT

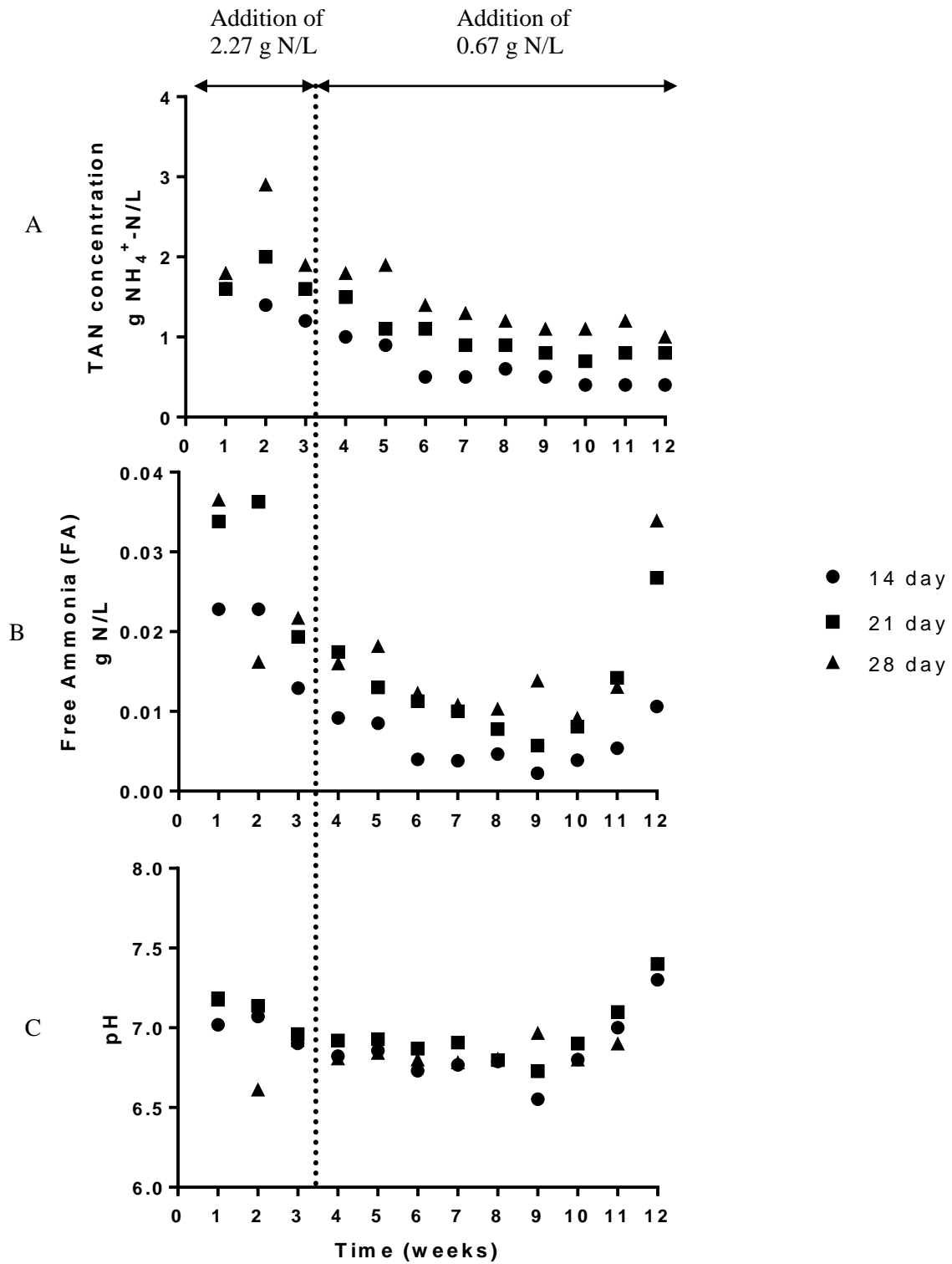

Figure 5.2 Comparison of TAN concentrations (A), FA concentrations (B) and pH (C) during Phase II for three reactors operating at varying SRT.

5.2.2.1 COD Mass Balance

The different portions of the COD mass balance discussed in chapter 4 are shown in Table 5.5. None of the reactors had a 100% COD mass balance. This could have been due to some assumptions made, such as the molecular formulas for the influent and effluent VS, volatilization of VFAs was ignored and growth kinetic constants assumed. Calculated COD % removal from the ADM1 model was compared to measured COD % removal from experimental data (Figure 5.3). There was no significant difference ($P = 0.0896$) between the measured % COD removal and calculated % COD removal.

Table 5.5: Calculated COD balance for the three reactors based Monod hydrolysis kinetics.

Parameter		Unit	14 day	21 day	28 day
Measured total influent particulate COD	X_{ti}	g COD/L	29.2	43.7	61.7
Acidogen biomass	Z_{AD}	g COD/L	4.11	6.09	8.52
Hydrolysis rate	μ	g COD/L-d	1.39	1.43	1.56
Residual biodegradable COD	S_{bp}	g COD/L	0.60	0.27	0.18
Unbiodegradable soluble COD	S_I	g COD/L	7.30	10.9	15.4
CH₄ concentration	S_m	g COD/L	15.1	23.2	33.7
Calculated total influent particulate COD	X_{ti}	g COD/L	27.1	40.5	57.8
COD balance		%	93.7	92.7	92.7

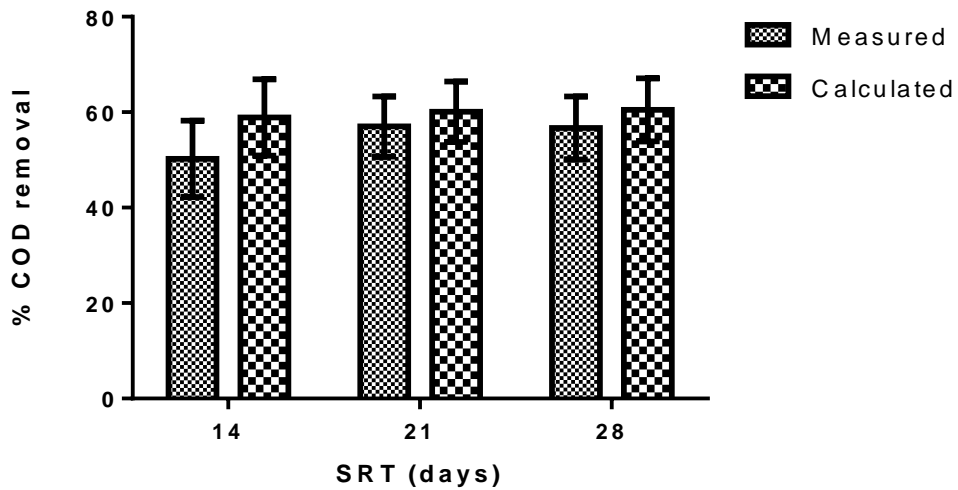

Figure 5.3: Comparison between % measured and % calculated COD removal

5.2.2.2 Nitrogen Mass Balance

Nitrogen mass balance values are shown on Table 5.6. The 14 and 28 day reactors had a N mass balance greater than 80%. N mass balances less than 80% can be attributed to loss mechanism in the reactors (Barker & Dold, 1995) such as volatilization of gaseous TAN or formation of struvite precipitates in the reactor that consist of NH_4^+ (Marti et al., 2008).

Table 5.6: Calculated influent and effluent N concentrations and N mass balance.

Parameter		Unit	14 day	21 day	28 day
Total influent N	C_{TI}	g N/L	2.91	4.84	5.84
Total effluent N	C_{TE}	g N/L	2.80	3.71	4.76
N mass balance		%	96.3	76.6	81.5

5.2.2.3 Phosphorus Mass Balance

Phosphorus mass balance values are shown on Table 5.7. With the assumption that metal phosphates precipitated into the solution in the reactors, each of the reactors had a mass balance indicating a loss mechanism for P was through metal precipitation.

Table 5.7: Calculated influent P and effluent P concentrations and P mass balance

Parameter	Unit	14 day	21 day	28 day
Influent P	P_{TIC} g P/L	0.86	1.28	1.70
Effluent P	P_{TE} g P/L	0.69	0.88	1.11
P mass balance	%	79.8	68.8	65.6

5.2.3 Centrate COD Bioavailability Results

Readily biodegradable COD (S_S) concentrations were calculated from respirometric curves using the general kinetic model (Young, 2012). Figure 5.4 was derived from the average of six measured OUR curves obtained during the 12 weeks of operation for each reactor. The average S_S concentrations are shown in Table 5.8. Since the influent COD concentrations varied between the three SRT reactors, a ratio was chosen to compare the quality and bioavailability of COD in the centrate for denitrification in a BNR process. The statistical difference between the reactors was also calculated.

Table 5.8: COD fraction, concentrations, centrate ratios and statistical difference between the three reactors.

Ratios	Unit	14 day	21 day	28 day	P value	Significant?
Soluble COD/Total COD	%	12.8	14.7	19.3	<0.0001	Yes
VFA COD/Total COD	%	3.13	3.80	5.78	<0.0001	Yes
S_S/Total COD	%	3.84	2.83	2.07	<0.0001	Yes
S_S/Soluble COD	%	30.0	19.6	10.6	<0.0001	Yes
S_S	g COD/L	0.93	0.85	0.86	0.82	No
S_S/NH_4^+-N	g COD/g N	1.20	0.73	0.56	0.03	Yes
Denitrification potential						
SMP	g COD/L	1.42	2.04	3.23	<0.0001	Yes
SMP/Soluble COD	%	68	69	70	0.76	No
Fraction S_S of stored VFA	%	0	0	64.9	<0.0001	Yes

S_S = Readily biodegradable COD; SMP = Soluble microbial products

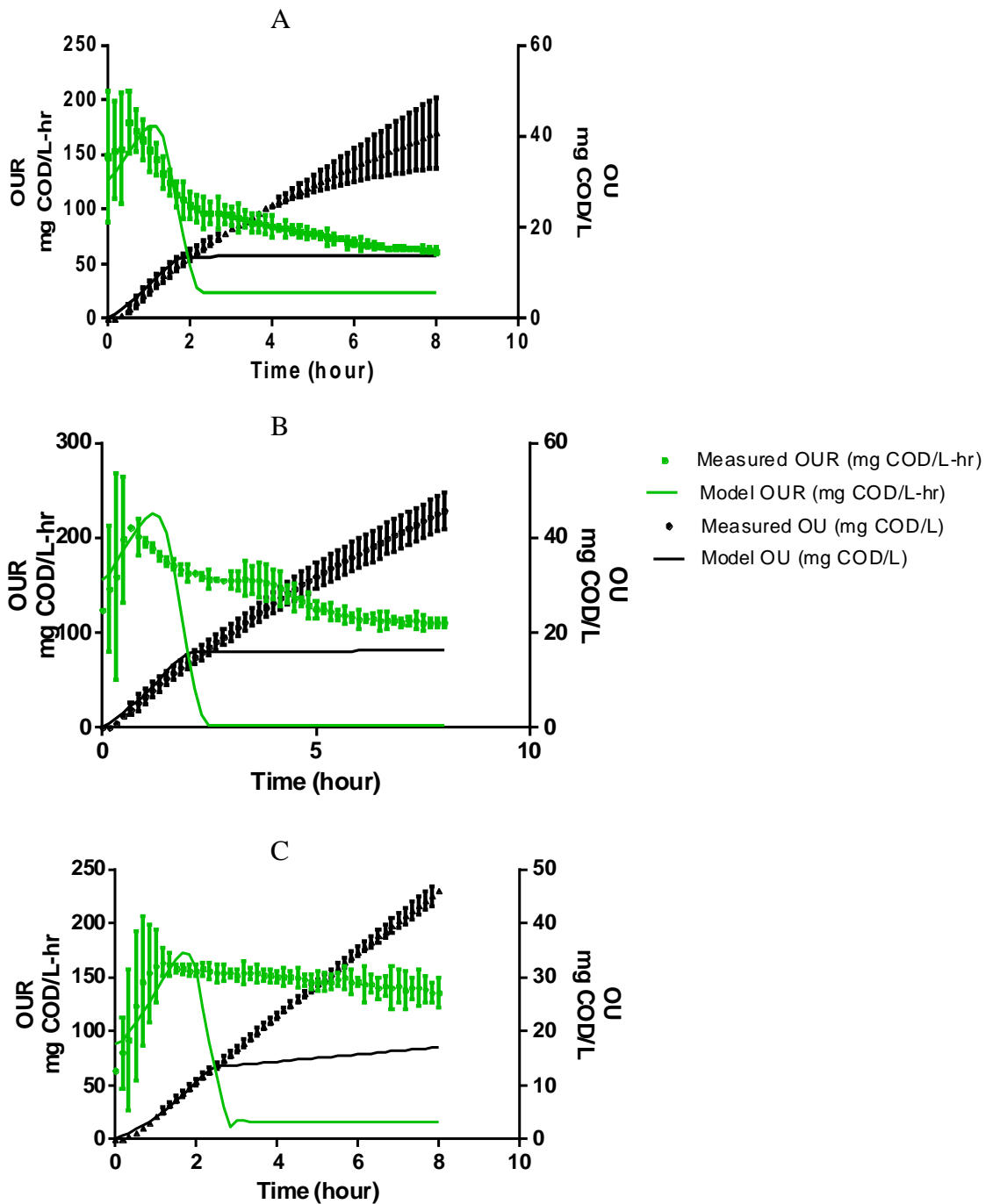

Figure 5.4: Measured and model OUR and OU respirometric curves for the three reactors during respirometry tests using the centrate (soluble COD) portion of swine AD effluent and MLVSS from a WWTP A: 14 day, B: 21 day and C: 28 day SRT

The mean S_s concentration as a percent of total COD and soluble COD increased with decreasing SRT (Table 5.8). In addition, VFAs in the centrate from the 14 and 21 day were fully utilized during the respirometer tests. Interestingly, only 35.1% of the VFA concentration in the centrate from the 28 day reactor was utilized during the respirometer test. In the 14 day reactor, the S_s concentration was higher than the VFA concentration in the centrate as illustrated in Figure 5.5. This could have been due to storage of AD centrate before running respirometer tests or experimental errors.

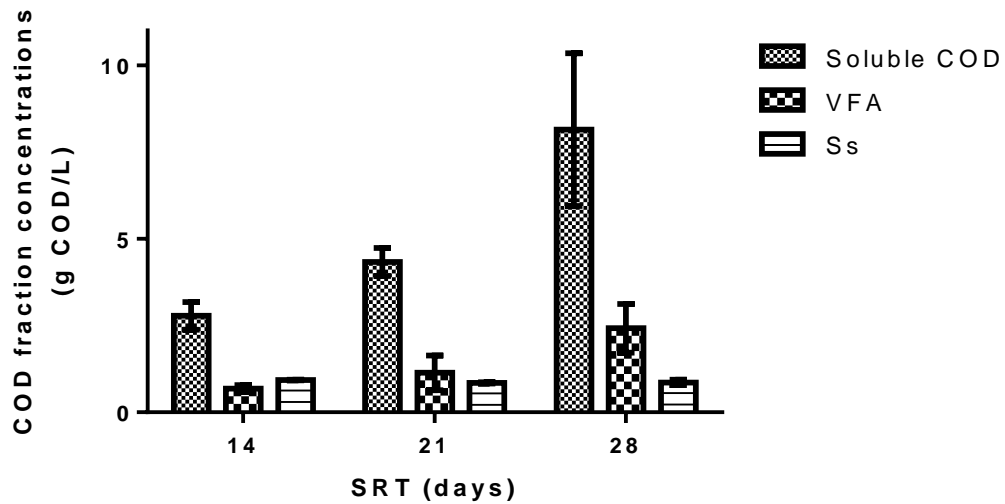

Figure 5.5: Average effluent soluble COD fractions in the three SRT reactors during Phase II.

5.2.4 Denitrification Test

As an additional test for the denitrification potential of the centrate, a simple denitrification test was performed with centrate from each reactor with an initial NO_3^- concentration of 1g NO_3^- -N/L. The initial NO_3^- concentration of 1g NO_3^- -N/L was used with the assumption that the average NH_4^+ -N concentration in the effluent from all three reactors would be nitrified in a BNR process. The results are shown in Figure 5.6.

Although the % NO_3^- removal varied between the reactors, only the 21 day and 28 day %

NO_3^- removal varied significantly ($P = 0.028$). The NO_3^- removal study did coincide with the denitrification potential. The 14 day reactor had both the highest denitrification potential and measured % NO_3^- removal. The 21 day reactor had a higher denitrification potential compared with the 28 day reactor; however, it had lower measured % NO_3^- removal. This may have been due to experimental error. Most importantly, none of the reactor's centrate was able to achieve 100% denitrification. A theoretical % NO_3^- removal was calculated with the assumption that all the S_S concentration derived from the respirometer data was utilized. This calculation produced less than 60% denitrification. This was further evidence that the centrate from the reactors cannot successfully be used as the sole carbon source in a BNR process.

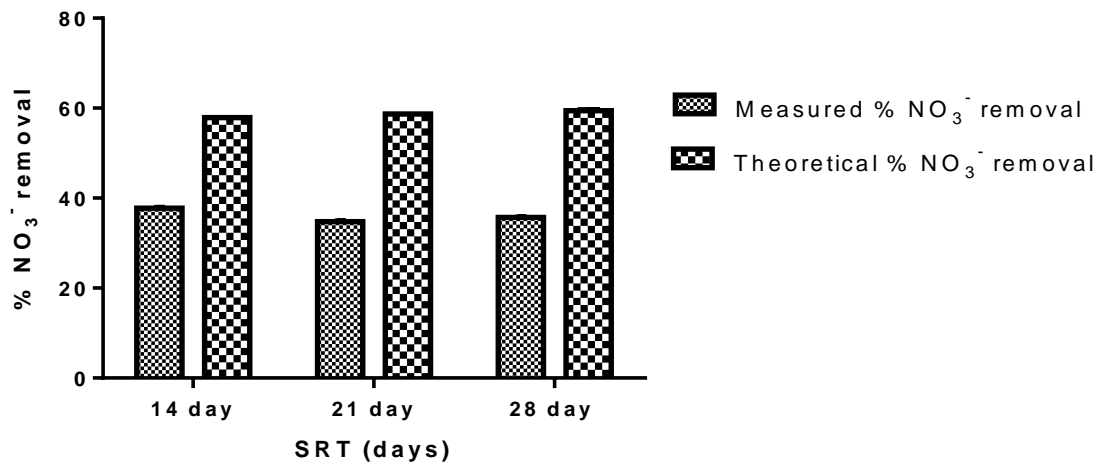

Figure 5.6: Results from a denitrification microcosm to measured NO_3^- removal with each reactor's centrate as carbon source (Note: No error bars are shown due to very low standard deviation)

CHAPTER 6: DISCUSSION

This section will primarily discuss the results of Phase II. VS removal, CH₄ yield, TAN and FA concentrations will be discussed in terms of SRT. The biodegradability of the COD portion of the centrate, effect of SMP, freezing and thawing of swine waste as well as NO₃⁻ removal will be discussed.

6.1 Volatile Solids Removal and Methane Yield as a Function of SRT

The main purposes for AD are VS removal and biogas production. The three SRTs were chosen to evaluate how VS removal and CH₄ yield were affected by differences in SRT at the same OLR. During the study it was observed that the reactor with the lowest SRT (14 days) and the lowest influent VS concentration consistently had the highest VS removal. Although the 14 day reactor had the highest % VS removal, the 21 day reactor had the highest biogas production and CH₄ yield throughout the 12 weeks. This could have been due to the fact that microorganisms with the shortest SRT may have had time to metabolize the solid substrates into organic acids but did not have adequate time to convert the organic acids into CH₄. The microorganisms in the longest SRT reactor may have had slower metabolic activity, leading to the 28 day SRT reactor having the lowest % VS removal (Gaudy & Blachly, 1985). To verify this, the hydrolysis rates calculated in Table 5.5 were divided by the total influent COD concentrations in Table 5.4 to yield a standardized hydrolysis rate, Figure 6.1. The standardized hydrolysis rate

increased with decreasing SRT and the difference in the rate was statistically significant ($P < 0.0001$) between the AD reactors.

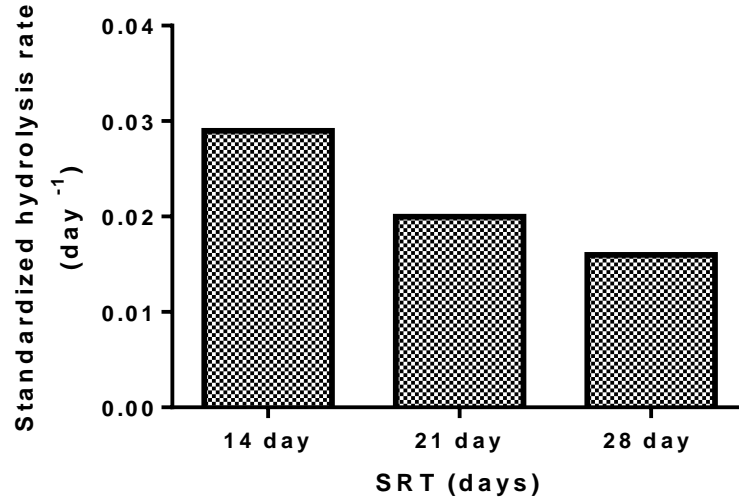

Figure 6.1: Standardized hydrolysis rate calculated by dividing hydrolysis rate by total influent COD concentration

Nges & Liu (2010) found that % VS removal decreased as SRT decreased; they attributed this to process imbalances at SRTs below 12 days. At this SRT the microorganisms do not have sufficient time and contact with the substrate leading to washout. The authors recommended an SRT between 12-15 days to maximize % VS removal and biogas production, which is in line with this study. The high VFA concentration observed in the 28 day SRT reactor may indicate that the methanogens were slightly overloaded and were slowly utilizing the organic acids to produce CH_4 . This resulted in a lower CH_4 yield compared to the other reactors. The VFA to alkalinity ratio (0.22) observed in the 28 day SRT reactor is also an indicator that this reactor may have been on the verge of a VFA imbalance.

Differences in CH_4 yield between the three reactors were not statistically significant. Under the experimental conditions in this study, the highest average CH_4

yield was at 21 day SRT, even though the 14 day SRT reactor had higher % CH₄ content in the biogas. As SRT increased, the microbial growth rate decreased along with the substrate utilization rates (Gaudy & Blachly, 1985). Therefore, from these results, when designing an AD system treating swine waste to maximize biogas production and % VS removal, an SRT between 14 - 21 days is recommended.

6.2 TAN and FA Concentrations

Spiking the reactors with 2.27 g N/L as urea during the first three weeks of Phase II caused the CH₄ yield to decrease. During week two, all reactors experienced a decrease in CH₄ yield as TAN concentration increased. The 28 day SRT reactor had the highest TAN concentration and lowest CH₄ yield. Although the 28 and 21 day SRT reactors had TAN concentrations within what is considered the inhibitory range, 1.7-5.0 g N/L (Magbanua et al., 2001; Zhang et al., 1997), CH₄ production continued, probably because the microorganisms were not inhibited by FA due to favorable pH (Figure 5.4). FA concentrations are shown in Table 6.1. Other authors have found that FA is inhibitory in the range of 0.7-1.1 g N/L (Angelidaki & Ahring 1993; Hansen et al., 1998).

Table 6.1: Phase II week 2 reactors' performance in terms of pH, CH₄ yield, TAN and FA concentrations.

Parameter	Unit	14 day	21 day	28 day
TAN	g NH ₄ ⁺ -N/L	1.43	1.95	2.89
FA	g N/L	0.023	0.036	0.016
pH		7.07	7.14	6.61
CH ₄ yield	m ³ CH ₄ /kg VS	0.24	0.21	0.16

After week three, the urea concentration was decreased to 0.67 g N/L to decrease the TAN concentration and improve CH₄ yield. With this decreased urea concentration, it took each reactor one SRT to adjust to the new urea concentration and for CH₄ yield to

increase (Table 5.1A). TAN levels never reached a steady concentration for any of the three reactors during the 12 weeks of operation during Phase II but continuously decreased each week as biogas production increased (Table 5.2A). TAN concentrations after week three, for the 14 day reactor were similar to those reported by other authors using AD for swine waste (Table 2.3). TAN concentrations after week three, for the 21 and 28 day reactors were higher than the values reported by other authors using AD to treat swine waste (Table 2.3). However, FA concentrations were below the inhibitory range and did not affect biogas production. This lead the reactors to have CH₄ yields within 0.30 m³ CH₄/kg VS added, the typical yield for AD of swine waste (Burton & Turner, 2003).

During Phase II, the 28 day reactor had an average TAN concentration within the inhibitory range and high VFA concentrations. However, high TAN and VFA concentrations led to stabilization of pH at near neutral values, leading to low FA concentrations that did not affect biogas production. This same trend was observed by Angelidaki & Ahring (1993), who treated cattle waste using AD. In addition, accumulation of VFA in the 28 day reactor indicated that the acetate utilizing methanogens, that are sensitive to high TAN concentrations, were inhibited. Although acetate consuming methanogens may have been inhibited by high levels of TAN (1.7-6.0 g N/L), biogas production continued. This phenomenon occurs when inhibited acetate utilizing methanogens and not-as-sensitive hydrogen utilizing methanogens form a syntrophic relationship. Hydrogen consuming methanogens degrade acetate to CO₂ and H₂ then use H₂ as an intermediate to form CH₄. Nonetheless, it should be noted that at first, high levels of TAN may have inhibited both groups of methanogens but due to

hydrogen utilizing methanogens' less sensitive nature, they may have been able to acclimate to the high TAN levels and biogas production continued (Angenent et al., 2002). Hydrogen utilizing methanogens have better energy gains, but most AD produce limited amounts of H_2 (Amani et al., 2010). Therefore, acetate utilizing methanogens were probably the more dominant methanogen species in the 28 day reactor.

6.3 Mass Balances

One of the analysis tools used in this thesis was performing a mass balance for COD and nutrients in the reactors. Mass balances are important because they assist in validating results and making them more comparable. In addition mass balances help to ensure the technology developed or proposed in the lab can be transferred to a full-scale operation in the field (Batstone et al., 2002). The molecular formula for the influent swine waste was assumed to be $C_6H_{13}O_5N$ and the effluent was $C_5H_7O_2N$ (Choi, 2007).

6.3.1 COD Mass Balance

None of the reactors had 100% COD mass balance. One of the factors that could have affected the COD mass balance results was that the ADM1 model did not account for volatilization of VFAs. During measurement of VFAs, it may be likely that some of the VFAs volatilized and were not accounted for in the VFA concentrations used to calculate the mass balance. Another factor, affecting the COD mass balance was the assumed influent and effluent molecular formulas. This study did not do any molecular analysis. Molecular formulas, derived by other authors, which were used in this study, may not have accurately represented the influent and effluent molecular formulas for this study. Experimental error may also explain why the COD balance was not 100%.

Although higher, the calculated % COD removal from the ADM1 model corresponded well to the measured % COD removal from the experimental data and there was no statistical difference between the two removal rates. Therefore the ADM1 model worked well in establishing a COD mass balance for AD of swine waste for this study.

6.3.2 Nitrogen Mass Balance

None of the reactors had 100% N mass balance. This could have been due to experimental error or volatilization of gaseous FA during regular reactor maintenance. Volatilization of gaseous FA was assumed to be negligible when calculating the N mass balance. The 21 day reactor had a mass balance less than 80%. Mass balances less than 80% can be attributed to loss mechanisms in the reactor (Barker & Dold, 1995). During operation of the reactors, it is likely that the 21 day reactor may have experienced additional volatilization of gaseous FA compared to the other reactors. It should be noted that during Phase II of this research, another research study was carried out investigating inactivation of *Ascaris sum* eggs during AD of swine waste. Only the 21 day reactor was used to carry out the *Ascaris sum* eggs inactivation study and required more recurrent opening of the reactor compared to the other two reactors. This opening of the reactor may have resulted to increased volatilization of gaseous FA in the 21 day reactor, which affected its N mass balance.

6.3.3 Phosphorus Mass Balance

With the assumption that metal phosphates precipitated in the reactors, each of the reactors had a mass balance indicating that the loss mechanism for P was through metal precipitation in the reactor. Attention has to be paid to this loss mechanism because it can cause unwanted increase in operational cost of a BNR process to remove metal phosphate

deposits (Marti et al., 2007). Alternatively, the biosolids from AD are rich in P, and can be used as a fertilizer.

6.4 COD and Denitrification Potential

The ratios of soluble COD/ total COD and VFA COD/ total COD varied between the reactors and this variation was due to differences in SRT and standardized hydrolysis rates. The 28 day SRT reactor had the highest ratio of soluble COD/total COD because of slower substrate utilization rates; however, the microorganisms had a longer time to hydrolyze the substrate into VFAs compared with the reactors with shorter SRTs.

The readily biodegradable COD (S_S) fraction ranged from 2-4% of total COD. However since the centrate is what is likely to be used in a BNR process, evaluating the S_S to soluble COD is more accurate. This fraction ranged from 11-30% and was highest in the 14 day SRT reactor. This fraction was within range of what other authors have found in AD swine waste (Obaja et al., 2005).

6.4.1 Evaluation of Biodegradable COD Fractions in the Centrate

During the respirometer tests, the test vessels that were fed with centrate from the 14 day and 21 day reactors, utilized all the VFAs. In fact the respirometer test indicated that the S_S concentrations from the 14 day reactor centrate were higher than the measured VFA concentrations (Figure 5.5). A statistical analysis for the measured VFA concentration and respirometer S_S concentrations for the 14 day reactor showed that these values were not significantly different at a P value of 0.061. This difference could have been due to experimental error when performing the VFA test or a calculation error when curve fitting the respirometer data. Also storing of the AD centrate before performing the respirometer tests may have lead to a slight increase in VFA concentrations. Moreover,

while VFA concentration analyses were performed on freshly obtained effluent, the respirometric tests were carried out 48 hours after the effluent was obtained and stored at 4°C. This storage may have also encouraged further degradation of the waste, further increasing S_S concentration available for the respirometer test (Mathieu & Etienne, 2000).

Unlike the 14 and 21 day reactors, that utilized all the VFAs concentrations during the respirometer tests, the test vessels with centrate from the 28 day reactor utilized only 35.1% of the VFA concentration in the centrate. The assumption made for this study was that the rest of the VFAs were stored inside the microorganisms' cells as polyhydroxybutyrate (PHB) (Van Loosdrecht et al., 1997). The amount of PHB stored in the cells depends on the F/M ratio used during the respirometer test. This study used an F/M ratio of 0.67, which was chosen based on prior studies that investigated S_S fraction of anaerobically digested swine waste. With this assumption, the microbial PHB storage process plays a significant role in the denitrification potential of the swine waste. PHB was added as part of the slowly biodegradable COD (X_S) thus recognizing that this waste had a high concentration of X_S . This result is similar to Boursier et al. (2005), who found that their anaerobically digested swine waste had a large fraction (up to 53%) of X_S . During a 20 hour respirometric test it was impossible to identify the X_S fraction of the waste, hence the lack of a clearly defined plateau in Figure 5.4 compared to Figure 2.8. Figure 6.2 shows the biodegradable portion of COD in the effluent. It is clear that the 28 day reactor had the highest concentration of X_S compared to the other reactors.

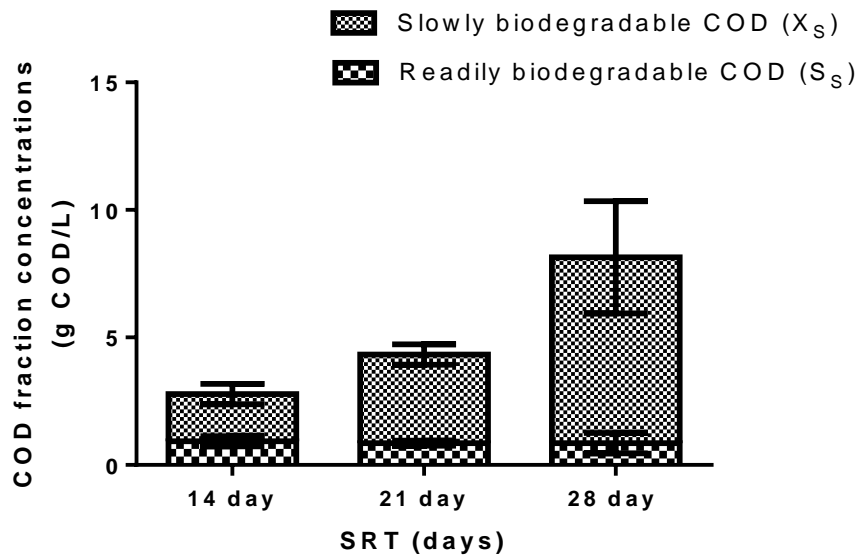

Figure 6.2: Biodegradable effluent COD fractions from the three reactors.

The denitrification potential of the centrate between the reactors was significantly affected by the SRT. During AD, hydrolysis can be the rate limiting step when the raw swine waste is converted to readily biodegradable substrates that can be used as internal carbon sources for denitrification. The hydrolysis rate of the swine waste depends on SRT. At lower SRTs the hydrolysis rate is faster but does not provide sufficient time for X_S fraction conversion to S_S . To increase the denitrification potential, Boursier et al. (2005) recommended an SRT of 40-60 days for ample time for the microorganisms to convert X_S to S_S . This is contrary to the results from this study that indicate denitrification potential increased with decreasing SRT. However this could have also been due to the fact that the 14 day SRT reactor had the lowest influent and effluent TAN concentrations. Investigating the same range of SRTs with the same influent TAN concentration would be recommended. In addition, earlier it was suggested an SRT of 12-15 day would increase % VS removal, which is in agreement with this study (Nges & Liu, 2010). Therefore when designing an AD for treating swine waste, the SRT chosen

will depend on the needs of the farmer; increasing biogas production or decreasing operation cost by utilizing an internal carbon source.

6.4.2 Evaluation of Soluble Microbial Products in the Centrate

If the recommended SRT range (40-60days) was to be applied, soluble microbial products (SMPs) concentrations cannot be ignored because SMPs constitute most of the effluent soluble COD (Ni, 2013). SMPs are made up of biomass associated products (BAP) and substrate utilization products (UAP) (Rittmann and McCarty, 2001). As SRT increases, BAPs increase due to the lower substrate utilization rate (Kuo et al., 1996). For this study the same trend was observed; SMP concentration increased with SRT increase. By normalizing SMP production to soluble effluent COD concentration, the % of SMP in the soluble effluent COD was approximately the same between the reactors, with no significant difference. This same trend was observed in other studies treating waste by AD (Kuo et al., 1996). Moreover Mesquita et al. (2010), studying effect of SRT on SMP production noted that SMP to soluble influent COD ratio did not significantly differ between 4 to 10 day SRTs in AD reactors.

6.4.3 Effect of Freezing and Thawing Swine Waste

As mentioned previously, the raw swine waste was frozen for long periods of time due to the distance between the farm and the laboratory. Freezing and thawing the waste may have impacted COD concentrations and indirectly affected the S_s fraction. Montusiewicz et al. (2010) investigated the effect of freezing and thawing sewage sludge before AD. The study found that the total COD and VS of the frozen sludge decreased, while soluble COD, alkalinity, VFA, soluble TN and TP increased compared with fresh sludge. The study also compared the effluent from the reactor fed with fresh sludge

versus frozen/thawed sludge. They found that total COD, soluble COD, VS, and VFA concentrations from the reactor fed with frozen/thawed sludge decreased while CH₄ yield increased. The difference between the influent and effluent between the two reactors was due to cellular disruption during freezing and thawing of the waste. This disruption releases intracellular material, which causes a decrease in influent total COD and VS. This soluble intracellular material caused the increase in soluble COD and VFA in the influent. Due to the increased concentration of soluble COD and VFA, which are easily utilized by microorganisms to produce CH₄, the effluent total COD, soluble COD, VS, and VFA concentrations decreased and CH₄ yield increased. They concluded that freezing and thawing of the sludge acted similar to a two-phase digestion process in which the growth of fermenting microorganisms and methanogens are maximized by separating the two groups (Ince, 1998).

In this study it is likely that the low SRTs did not accommodate S_S conversion to X_S in the reactors and freezing/thawing process encouraged CH₄ production, both of which may have resulted in low S_S concentration in the effluent and low denitrification potential of the waste. Moreover, while VFA concentration analyses were performed on freshly obtained effluent, the respirometric tests were performed with centrate that had been stored at 4°C for 48 hours. This storage may have also encouraged further degradation of the waste, further decreasing S_S concentration (Mathieu & Etienne, 2000). Although the three reactors' S_S concentrations did not differ significantly, the denitrification potential did vary significantly between the reactors. It can therefore be concluded that the three SRTs chosen did not affect bioavailability of S_S but affected the denitrification potential.

6.5 Nitrate Removal by Centrate

Since centrate from each of the reactor did not achieve 100% measured or theoretical NO_3^- removal, the centrate from the reactors cannot be used as the sole carbon source in a BNR process. Obaja et al. (2005) used 25% of AD effluent treating swine waste as an internal carbon source with 75% acetic acid (external carbon source) to achieve 99.9% NO_3^- removal in a BNR process. The 25% addition of internal carbon source saved operational cost and was more sustainable than using 100% acetic acid. Therefore, the centrate from this study's AD can be used in addition to an external carbon source to lower the cost of operating a BNR process.

CHAPTER 7: CONCLUSIONS AND RECOMMENDATIONS

The specific objectives of this research were to; (1) evaluate how different SRTs in the AD affect the denitrification potential of the centrate from the AD in a BNR process (2) to offer guidelines on a favorable SRT for biogas production and methane yield, while providing adequate bioavailable organic carbon to provide an electron donor for denitrification, (3) provide a critical literature review of how different operational parameters affect the performance of AD systems treating swine manure and (4) perform a mass balance on the organic carbon and nutrients in an AD system.

The main conclusions were:

1. When designing an AD system treating swine waste an SRT between 14-21 days is recommended to maximize biogas production and % VS removal.
2. Due to TAN and FA concentrations within a reasonable range to prevent inhibition, all three reactors were able to continuously produce biogas and the CH₄ yield was within the typical range for AD of swine waste.
3. None of the reactors achieved the 5 g COD/g N needed for complete denitrification using internal organic carbon. This may have been due to: (1) high concentrations of slowly biodegradable COD that was not converted to readily biodegradable COD or (2) freezing and thawing of the swine waste, which encouraged increase of CH₄ yield, % VS and % VFA removal.
4. The concentration of readily biodegradable COD was not statistically different between the reactors but the different SRTs significantly influenced the

denitrification potential. In general, shorter SRTs may have increased the denitrification potential; however, this could have been mainly due to low influent and effluent TAN concentrations as SRT decreased.

5. An external carbon source is required to achieve 100% NO_3^- removal; however, utilizing the readily biodegradable COD fraction in the centrate can reduce operational cost of BNR process.
6. Good COD and nutrient balances indicate that there were minimal loss mechanisms in the reactors pointing to good design and operation of the reactors. Metal phosphate precipitation in the reactors is a concern for AD operation.

Some recommendations to follow this research are:

1. To investigate how the denitrification potential of centrate from AD of swine waste, % VS removal and CH_4 yield are affected at a wider range of SRTs, for example between 12 – 60 days.
2. To carry out the same experiments with fresh swine waste and not frozen/thawed swine waste
3. To investigate how changes in OLR affect the denitrification potential of centrate from AD of swine.
4. To investigate how a larger volume, field AD reactor performance is affected in terms of the denitrification potential, % VS removal, CH_4 yield and TAN concentrations.

REFERENCES

- Amani, T., Nosrati, M., & Sreerishnan, T. R. (2010). Anaerobic digestion from the viewpoint of microbiological, chemical, and operational aspects - a review. *Environmental Reviews*, 18, 255-278. doi: 10.1139/A10-011
- APHA (2012). *Standard methods for the examination of water and wastewater* (32nd ed.). Washington, D.C: American Public Health Association.
- Angelidaki I. & Sanders W. (2004). Assessment of the anaerobic biodegradability of macropollutants. *Reviews in Environmental Science and Bio/Technology*, 3, 117-129.
- Angelidaki, I. & Ahring, B.K. (1993). Thermophilic anaerobic digestion of livestock waste: The effect of ammonia. *Applied Microbiology and Biotechnology*, 38, 560-564.
- Angenent, L.T., Zheng, D.D., Sung, S.H., et al. (2002). Microbial community structure and activity in a compartmentalized, anaerobic bioreactor. *Water Environment Research*, 74 (5), 450+. doi: 10.2175/106143002X140242
- Appels, L., Lauwers, J., Degreè, J., Helsen, L., Lievens, B., Willems, K., . . . Dewil, R. (2011). Anaerobic digestion in global bio-energy production: Potential and research challenges. *Renewable and Sustainable Energy Reviews*, 15(9), 4295-4301. doi: 10.1016/j.rser.2011.07.121
- Barker, P. S., & Dold, P. L. (1995). COD and nitrogen mass balances in activated-sludge systems. *Water Research*, 29(2), 633-643. doi: 10.1016/0043-1354(94)00155-Z
- Batstone, D., Keller, J., Angelidaki, I., Kalyuzhnyi, S., Pavlostathis, S., Rozzi, A., . . . Vavilin, V. (2002). The IWA anaerobic digestion model no 1 (ADM1). *Water Science and Technology*, 45(10), 65-73.
- Bernet, N., & Béline, F. Challenges and innovations on biological treatment of livestock effluents. *Bioresource Technology*, 100, 5431-5436. doi: 10.1016/j.biortech.2009.02.003
- Birgand, F., Skaggs, R. W., Chescheir, G. M., & Gilliam, J. W. (2007). Nitrogen removal in streams of agricultural catchments - A literature review. *Critical Reviews in Environmental Science and Technology*, 37(5), 381-487. doi: 10.1080/10643380600966426

- Boursier, H., Beline, F., & Paul, E. (2005). Piggery wastewater characterisation for biological nitrogen removal process design. *Bioresource Technology*, 96(3), 351-358. doi: 10.1016/j.biortech.2004.03.007
- Bowman, R., Dahab, M., Middlebrooks, J.E, Pearson, G. F., Reed S. (2002). Wastewater technology fact sheet: Anaerobic lagoons. Retrieved September 13, 2012, from http://water.epa.gov/scitech/wastetech/upload/2002_10_15_mtb_alagoons.pdf
- Buekens, A. (2005). Energy recovery from residual waste by means of anaerobic digestion technologies. Conference: *The Future of Residual Waste Management in Europe*, 17-18 November, Luxemburg.
- Burns, R. T. & Moody, L.B. (2002). Phosphorus recovery from animal manures using optimized struvite precipitation. *Proceedings of Coagulants and Flocculants: Global Market and Technical Opportunities for Water Treatment Chemicals*,
- Burton, C. H. & Turner, C. (2003). *Manure management: Treatment strategies for sustainable agriculture*. Silsoe: Silsoe Research Institute.
- Carlos D.M., Filipe, C.P., Grady, L.Jr. (1998). *Biological Wastewater Treatment* (2nd ed.) New York: Marcel Dekker, Inc.
- Celen I., Buchanan J. R., Burns R. T., Robinson R.B., Raman, D.R. (2006). Using a chemical equilibrium model to predict amendments required to precipitate phosphorus as struvite in liquid swine manure. *Water Research*, 41(2007), 1689-1696.
- Chen, Y., Cheng, J. J., & Creamer, K. S. (2008). Inhibition of anaerobic digestion process: A review. *Bioresource Technology*, 99(10), 4044-4064. doi: 10.1016/j.biortech.2007.01.057
- Chen, T. H., Shyu, W.H. (1996). Performance of four types of anaerobic reactors in treating very dilute dairy wastewater. *Biomass & Bioenergy*, 11 (5), 431-440.
- Choi, E. (2007). *Piggery waste management: Towards a sustainable future*. London: IWA Publishing.
- Chudoba, J. (1985). Quantitative estimation in COD units of refractory organic-compounds produced by activated-sludge microorganisms. *Water Research*, 19(1), 37-43. doi: 10.1016/0043-1354(85)90320-3
- Chynoweth, D. P., Wilkie, A. C., & Owens, J. M. (1999). Anaerobic treatment of piggery slurry - review. *Asian-Australasian Journal of Animal Sciences*, 12(4), 607-628.
- Çokgör, E., Sozen, S., Orhon, D., & Henze, M. (1998). Respirometric analysis of activated sludge behaviour - I. assessment of the readily biodegradable substrate. *Water Research*, 32(2), 461-475.

- Constantine, T., Murthy, S., Bailey, W., Benson, L., Sadick, T., Daigger, G. (2005) Alternatives for Treating High Nitrogen Liquor From Advanced Anaerobic Digestion at the Blue Plains AWTP. Proceedings of the Water Environment Federation, WEFTEC 2005: Session 1 through Session 10 548-561(14). doi: <http://dx.doi.org/10.2175/193864705783868007>
- Converse, J. C., Graves, R. E., & Evans, G. W. (1977). Anaerobic degradation of dairy manure under mesophilic and thermophilic temperatures. *Transactions of the ASAE*, 20(2), 336-340.
- de Bok, F. A. M., Plugge, C. M., Stams, A. J. M. (2004). Interspecies electron transfer in methanogenic propionate degrading consortia. *Water Research*, 38(6), 1368-1375. doi: 10.1016/j.watres.2003.11.028
- De Lucas, A., Canizares, P., Rodriguez, L., & Villasenor, J. (2000). Respirometric determination of the readily biodegradable COD produced in the anaerobic stage of a biological phosphorus removal process. *Journal of Environmental Science and Health Part A-Toxic/hazardous Substances & Environmental Engineering*, 35(1), 49-64.
- Demirer, G., & Chen, S. (2005). Anaerobic digestion of dairy manure in a hybrid reactor with biogas recirculation. *World Journal of Microbiology & Biotechnology*, 21(8-9), 1509-1514. doi: 10.1007/s11274-005-7371-6
- Deng, L., Zheng, P., Chen, Z., & Mahmood, Q. (2008). Improvement in post-treatment of digested swine wastewater. *Bioresource Technology*, 99(8), 3136-3145. doi: 10.1016/j.biortech.2007.05.061
- Dold, C., & Holland, C. V. (2011). *Ascaris and ascariasis*. *Microbes and Infection*, 13(7), 632-637. doi: 10.1016/j.micinf.2010.09.012
- Dold, P., & Marais, G. (1986). Evaluation of the general activated-sludge model proposed by the IAWPRC task group. *Water Science and Technology*, 18(6), 63-89.
- Duran, M., & Speece, R. (1999). Biodegradability of residual organics in the effluent of anaerobic processes. *Environmental Technology*, 20(6), 597-605. doi: 10.1080/09593332008616854
- Ekama, G., Dold, P., & Marais, G. (1986). Procedures for determining influent cod fractions and the maximum specific growth-rate of heterotrophs in activated-sludge systems. *Water Science and Technology*, 18(6), 91-114.
- Elmitwalli, T., Soellner, J., De Keizer, A., Bruning, H., Zeeman, G., & Lettinga, G. (2001). Biodegradability and change of physical characteristics of particles during anaerobic digestion of domestic sewage. *Water Research*, 35(5), 1311-1317. doi: 10.1016/S0043-1354(00)00377-8

- Ferrer, I., Gamiz, M., Almeida, M., & Ruiz, A. (2009). Pilot project of biogas production from pig manure and urine mixture at ambient temperature in Ventanilla (Lima, Peru). *Waste Management*, 29(1), 168-173. doi: 10.1016/j.wasman.2008.02.014
- Gaudy, A. F., & Blachly, T. R. (1985). A study of the biodegradability of residual COD. *Journal Water Pollution Control Federation*, 57(4), 332-338.
- Gerardi, M. H. (2003). *The microbiology of anaerobic digesters electronic resource*. Hoboken, N.J: Wiley-Interscience.
- GTZ/EnDeV. (2010). Installation manual for Low-cost polyethylene tube digesters. Retrieved 11 26, 2012, from https://energypedia.info/images/1/19/Low_cost_polyethylene_tube_installation.pdf
- Haandel, A. V., & Lubbe, J. V. D. (2007). *Handbook biological waste water treatment: Design and optimisation of activated sludge systems*. Leidschendam, The Netherlands: Quist Publishing.
- Hansen, K. H., Angelidaki, I., & Ahring, B. K. (1998). Anaerobic digestion of swine manure: Inhibition by ammonia. *Water Research*, 32(1) doi: 10.1016/S0043-1354(97)00201-7
- Henze, M. (1992). Characterization of waste-water for modeling of activated-sludge processes. *Water Science and Technology*, 25(6), 1-15.
- Hill, D.T., Holmberg, R.D. (1988). Long chain volatile fatty acids relationships in anaerobic digestion of swine waste. *Biological Wastes*, 23, 195-214. doi: 10.1016/0269-7483(88)90034-1
- Hill, D., & Bolte, J. (2000). Methane production from low solid concentration liquid swine waste using conventional anaerobic fermentation. *Bioresource Technology*, 74(3), 241-247. doi: 10.1016/S0960-8524(00)00008-0
- Husain, A. (1998). Mathematical models of the kinetics of anaerobic digestion - A selected review. *Biomass & Bioenergy*, 14(5-6), 561-571. doi: 10.1016/S0961-9534(97)10047-2
- Im, J., & Gi, K. (2011). Effect of anaerobic digestion on the high rate of nitrification, treating piggery wastewater. *Journal of Environmental Sciences-China*, 23(11), 1787-1793. doi: 10.1016/S1001-0742(10)60649-3
- Ince, O. (1998). Performance of a two-phase anaerobic digestion system when treating dairy wastewater. *Water Research*, 32(9), 2707-2713. doi: 10.1016/S0043-1354(98)00036-0
- Kalyuzhnyi, S., Sklyar, V., Fedorovich, V., Kovalev, A., Nozhevnikova, A., & Klapwijk, A. (1999). The development of biological methods for utilisation and treatment of diluted manure streams. *Water Science and Technology*, 40(1) 223-229. doi: 10.1016/S0273-1223(99)00388-1

- Kaparaju, P., & Rintala, J. (2005). Anaerobic co-digestion of potato tuber and its industrial by-products with pig manure. *Resources Conservation and Recycling*, 43(2) 175-188. doi: 10.1016/j.resconrec.2004.06.001
- Khanal, S. (2009). *Anaerobic biotechnology for bioenergy production principles and applications*. Hoboken: John Wiley & Sons, Inc.
- Kossmann, W., Pönitz, U., Habermehl, S., Hörz, T., Krämer, P., Klingler, B., Euler, H. (1999). *Biogas - application and product development: Biogas digest (volume II)*. Germany: GTZ.
- Krylova, N., Khabiboulline, R., Naumova, R., & Nagel, M. (1997). The influence of ammonium and methods for removal during the anaerobic treatment of poultry manure. *Journal of Chemical Technology and Biotechnology*, 70(1), 99-105. doi: 10.1002/(SICI)1097-4660(199709)70:1<99::AID-JCTB684>3.0.CO;2-C
- Kuo, W., Sneve, M., & Parkin, G. (1996). Formation of soluble microbial products during anaerobic treatment. *Water Environment Research*, 68(3), 279-285. doi: 10.2175/106143096X127712
- Leitao, R., van Haandel, A., Zeeman, G., & Lettinga, G. (2006). The effects of operational and environmental variations on anaerobic wastewater treatment systems: A review. *Bioresource Technology*, 97(9), 1105-1118. doi: 10.1016/j.biortech.2004.12.007
- Lin, A. Y., Ergas, S., Cunningham, J., Trotz, M. (2012) Precipitation of Phosphate Minerals from Effluent of Anaerobically Digested Swine Manure. (Masters' thesis). University of South Florida, Tampa, FL.
- Loewenthal, R. E., Kornmuller, U. R. C., & vanHeerden, E. P. (1995). Modeling struvite precipitation in anaerobic treatment systems. *Water Science and Technology*, 30(12), 107-116.
- Lu, Y., Wang, Y., Shen, S. F., Yan, L. H., Zhai, S. J., Chen, B. J., . . . Zhou, S. F. (2010). Biodegradation of organic compounds from coking wastewater with UASB reactor. *Water Science and Technology*, 62(8), 1784-1790. doi: 10.2166/wst.2010.543
- Magbanua, B. S., Adams, T. T., & Johnston, P. (2001). Anaerobic codigestion of hog and poultry waste. *Bioresource Technology*, 76(2) doi: 10.1016/S0960-8524(00)00087-0
- Magrí, A., & Flotats, X. (2008). Modelling of biological nitrogen removal from the liquid fraction of pig slurry in a sequencing batch reactor. *Biosystems Engineering*, 101(2), 239-259. doi: 10.1016/j.biosystemseng.2008.08.003
- Marti, N., Bouzas, A., Seco, A., & Ferrer, J. (2008). Struvite precipitation assessment in anaerobic digestion processes. *Chemical Engineering Journal*, 141(1-3), 67-74. doi: 10.1016/j.cej.2007.10.023

- Massé, D., Gilbert, Y., & Topp, E. (2011). Pathogen removal in farm-scale psychrophilic anaerobic digesters processing swine manure. *Bioresource Technology*, *102*(2), 641-646. doi: 10.1016/j.biortech.2010.08.020
- Massé, D., & Droste, R. (2000). Comprehensive model of anaerobic digestion of swine manure slurry in a sequencing batch reactor. *Water Research*, *34*(12), 3087-3106. doi: 10.1016/S0043-1354(00)00064-6
- Mateju, V., Cizinska, S., Krejci, J., & Janoch, T. (1992). Biological water denitrification - a review. *Enzyme and Microbial Technology*, *14*(3), 170-183. doi: 10.1016/0141-0229(92)90062-S
- Mathieu, S., & Etienne, P. (2000). Estimation of wastewater biodegradable COD fractions by combining respirometric experiments in various So/Xo ratios. *Water Research*, *34*(4), 1233-1246. doi: 10.1016/S0043-1354(99)00241-9
- Mathieu, S., Urbain, V., Ginestet, P., Audic, M., & Paul, E. (2001). Application of COD fractionation by a new combined technique: Comparison of various wastewaters and sources of variability. *Water Science and Technology*, *43*(1), 181-190.
- Melcer, H., et al. (2003). *Methods for wastewater characterization in activated sludge modeling*. Alexandria, VA; London, U.K.: Water Environment Federation; IWA Pub.
- Mesquita, P. L., Aquino, S. F., Xavier, A. L., et al. (2010). Soluble Microbial Product (SMP) Characterization in Bench-Scale Aerobic And Anaerobic CSTRs Under Different Operational Conditions. *Brazilian Journal of Chemical Engineering*, *27* (1), 101-111.
- Mihelcic, J. R., Zimmerman, J. B., & Auer, M. T. (2011). *Environmental engineering : Fundamentals, sustainability, design*. Hoboken, N. J: Wiley.
- Montgomery, H. A. C., Dymock, J. F., & Thom, N. S. (1962). Rapid colorimetric determination of organic acids and their salts in sewage-sludge liquor. *Analyst*, *87*(1041), 949-&. doi: 10.1039/an9628700949
- Montusiewicz, A., Lebiocka, M., Rozej, A., Zacharska, E., & Pawlowski, L. (2010). Freezing/thawing effects on anaerobic digestion of mixed sewage sludge. *Bioresource Technology*, *101*(10), 3466-3473. doi: 10.1016/j.biortech.2009.12.125
- Moser, M.A. (ND) Anaerobic Digesters Control Odors, Reduce Pathogens, Improve Nutrient Manageability, Can be Cost Competitive with Lagoons, and Provide Energy Too. Resource Conservation Management. Retrived from http://www.epa.gov/agstar/resources/man_man.html Undated on September 11, 2012.

- Ndegwa, P. M., Hamilton, D. W., Lalman, J. A., & Cumba, H. J. (2005). Optimization of anaerobic sequencing batch reactors treating dilute swine slurries. *Transactions of the ASAE*, 48(4), 1575-1583.
- Nges, I. A., & Liu, J. (2010). Effects of solid retention time on anaerobic digestion of dewatered-sewage sludge in mesophilic and thermophilic conditions. *Renewable Energy*, 35(10), 2200-2206. doi: 10.1016/j.renene.2010.02.022
- Ni, B.J., Yu, H.Q. (2012). Microbial Products of Activated Sludge in Biological Wastewater Treatment Systems: A Critical Review. *Critical Reviews in Environmental Science and Technology*, 42 (2), 187-223. doi: 10.1080/10643389.2010.507696
- Nishio, N., & Nakashimada, Y. (2007). Recent development of anaerobic digestion processes for energy recovery from wastes. *Journal of Bioscience and Bioengineering*, 103 (2), 105-112. doi: 10.1263/jbb.103.105
- Nozhevnikova, A. N., Simankova, M. V., Litt, Yu. V. (2012) Application of the microbial process of anaerobic ammonium oxidation (ANAMMOX) in biotechnological wastewater treatment. *Applied Biochemistry and Microbiology*, 48 (8), 667-684. doi: 10.1134/S0003683812080042
- Nuchdang, S., & Phalakornkule, C. (2012). Anaerobic digestion of glycerol and co-digestion of glycerol and pig manure. *Journal of Environmental Management*, 101, 164-172. doi: 10.1016/j.jenvman.2012.01.031
- Obaja, D., Mace, S., & Mata-Alvarez, J. (2005). Biological nutrient removal by a sequencing batch reactor (SBR) using an internal organic carbon source in digested piggery wastewater. *Bioresour Technol*, 96(1) doi: 10.1016/j.biortech.2004.03.002
- Ocwieja, S. M. (2010). *Life cycle thinking assessment applied to three biogas projects in central Uganda*. (Master's thesis) Michigan Technological University, Houghton, MI.
- Orhon, D., & Çokgor, E. (1997). COD fractionation in wastewater characterization - the state of the art. *Journal of Chemical Technology and Biotechnology*, 68(3), 283-293. doi: 10.1002/(SICI)1097-4660(199703).
- Ozturk, I. (1999). *Anaerobic biotechnology and its applications in waste treatment*. Istanbul: Turkish Water Foundation Publishing Corp.
- Pew Oceans Commission (2003). *America's living oceans: Charting a course for sea change: A report to the nation: Recommendations for a new ocean policy: Summary report*. Arlington, VA.: Pew Oceans Commission.
- Ra, C., Lo, K., Shin, J., Oh, J., & Hong, B. (2000). Biological nutrient removal with an internal organic carbon source in piggery wastewater treatment. *Water Research*, 34(3), 965-973. doi: 10.1016/S0043-1354(99)00189-X

- Rittmann, B. E., & McCarty, P. L. (2001). *Environmental biotechnology : Principles and applications*. Boston, MA.: McGraw-Hill.
- Sakar, S., Yetilmezsoy, K., & Kocak, E. (2009). Anaerobic digestion technology in poultry and livestock waste treatment - a literature review. *Waste Management & Research*, 27(1), 3-18. doi: 10.1177/0734242X07079060
- Sanchez, E. P., Monroy, O., Canizares, R. O., Travieso, L., & Ramos, A. (1995). A preliminary-study of piggery waste treatment by an upflow sludge bed anaerobic reactor and a packed-bed anaerobic reactor. *Journal of Agricultural Engineering Research*, 62(2), 71-75. doi: 10.1006/jaer.1995.1065
- Siedlecka, E. M., Kumirska, J., Ossowski, T., Glamowski, P., Golebiowski, M., Gajdus, J., Stepnowski, P. (2008). Determination of volatile fatty acids in environmental aqueous samples. *Polish Journal of Environmental Studies*, 17(3), 351-356.
- Sötemann, S., Ristow, N., Wentzel, M., & Ekama, G. (2005a). A steady state model for anaerobic digestion of sewage sludges. *Water SA*, 31(4), 511-527.
- Sötemann, S., van Rensburg, P., Ristow, N., Wentzel, M., Loewenthal, R., & Ekama, G. (2005b). Integrated chemical/physical and biological processes modelling part 2 - anaerobic digestion of sewage sludges. *Water SA*, 31(4), 545-568.
- Strik, D.P.B.T.B., Domnanovich, A.M., Holubar, P. (2006). A pH-based control of ammonia in biogas during anaerobic digestion of artificial pig manure and maize silage. *Process chemistry*, 41, 1235-1238
- Suidan, M.T., Najm, J. T., Pfeffer, J.T., Wang, Y.T. (1988). Anaerobic Biodegradation of Phenol: Inhibition Kinetics and System Stability. *Journal of Environmental Engineering*, 114 (6), 1359-1376. doi: [http://dx.doi.org/10.1061/\(ASCE\)0733-9372\(1988\)114:6\(1359\)](http://dx.doi.org/10.1061/(ASCE)0733-9372(1988)114:6(1359))
- Szögi, A.A., Vanotti, M.B., Hunt, P.G. (2006). Dewatering of phosphorus extracted from liquid swine waste. *Bioresource Technology*. 97, 183-190.
- Tanaka, Y., & Suzuki, K. (2004). New technology for swine treatment. *Farming Japan*, 38(1), 10-16.
- Tchobanoglous, G., Burton, F. L., Stensel, H. D. (2003). *Wastewater engineering : Treatment and reuse* (4th ed. / revised by George Tchobanoglous, Franklin L. Burton, H., David, Stensel.). Boston, MA.: McGraw-Hill.
- Topp, E., Scott, A., Lapen, D. R., et al. (2009). Livestock waste treatment systems for reducing environmental exposure to hazardous enteric pathogens: Some considerations. *Bioresource Technology*, 100 (22), 5395-5398. doi: 10.1016/j.biortech.2008.11.001
- Troyer, S. J., Ellis, T. G., & Dague, R. R., (1997). Effects of ammonia inhibition on the anaerobic sequencing batch reactor. *Proceedings of the 1997 29th Mid-Atlantic Industrial and Hazardous Waste Conference*, Blacksburg, VA, USA. 12-21.

- USEPA. (2000). 2000 national water quality inventory. Retrieved September 12, 2012, from http://water.epa.gov/lawsregs/guidance/cwa/305b/2000report_index.cfm
- USEPA. (2002). National pollutant discharge elimination system permit regulation and effluent limitation guidelines and standards for concentrated animal feeding operations(CAFOs). Retrieved September 20, 2012, from Final Rule
- USEPA. (2007). Struvite: Summary and operation issues. Retrieved November 10, 2012, from http://www.epa.gov/etv/pubs/08_vr_thermoenergy_ch4.pdf
- USEPA. (2008). EPA administered permit programs: The national pollutant discharge elimination system. Retrieved October 1, 2012, from <http://www.epa.gov/compliance/monitoring/programs/cwa/npdes.html>
- van Loosdrecht, M. C. M., Pot, M. A., & Heijnen, J. J. (1997). Importance of bacterial storage of polymers in bioprocesses. *Water Science and Technology*, 35(1), 41-47. doi: 10.1016/S0273-1223(96)00877-3
- Vandenburgh, S. R., & Ellis, T. G. (2002). Effect of varying solids concentration and organic loading on the performance of temperature phased anaerobic digestion process. *Water Environment Research*, 74(2), 142-148. doi: 10.2175/106143002X139857
- Vavilin, V., Rytov, S., & Lokshina, L. (1996). A description of hydrolysis kinetics in anaerobic degradation of particulate organic matter. *Bioresource Technology*, 56(2-3), 229-237. doi: 10.1016/0960-8524(96)00034-X
- Wei, Y., Li, Y., Ye, Z. (2010). Enhancement of removal efficiency of ammonia nitrogen in sequencing batch reactor using natural zeolite. *Environmental Earth Sciences*, 60 (7), 1407-1413. doi: 10.1007/s12665-009-0276-1
- Wentzel, M. C., Mbewe, A., & Ekama, G. A. (1995). Batch test for measurement of readily biodegradable COD and active organism concentrations in municipal wastewaters. *Water SA*, 21(2), 117-124.
- Westerman, P. W., & North Carolina Cooperative Extension Service. (2008). *Biogas anaerobic digester considerations for swine farms in North Carolina*. Raleigh, NC.: N.C. Cooperative Extension Service.
- Wilkie, A. C. (2005). *Anaerobic digestion: Biology and benefits*. Ithaca, NY, USA: Natural Resource, Agriculture, and Engineering Service, Cornell University.
- Willis, R., Montgomery, M., & Allen, P. (1996). Improved method for manual, colorimetry determination of total Kjeldahl nitrogen using salicylate. *Journal of Agricultural and Food Chemistry*, 44(7), 1804-1807. doi: 10.1021/jf950522b
- Wittmann, C., Zeng A.P., & Deckwer, W. D. (1995). Growth inhibition by ammonia and use of a pH-controlled feeding strategy for the effective cultivation of mycobacterium chlorophenicum. *Applied Microbiology and Biotechnology*, 44, 519-525.

- Young, J. C. (2012). Personal communication, November 11, 2012.
- Young, J. C., & Cowan, R. M., (2004). *Respirometry for environmental science and engineering*. Springdale, AS.: SJ Enterprises.
- Zarkadas, I. S., & Pilidis, G. A. (2011). Anaerobic co-digestion of table olive debittering & washing effluent, cattle manure and pig manure in batch and high volume laboratory anaerobic digesters: Effect of temperature. *Bioresource Technology*, 102(8), 4995-5003. doi: 10.1016/j.biortech.2011.01.065
- Zeeman, G., Wiegant, W. M., Kostertreffers, M. E., & Lettinga, G. (1985). The influence of the total ammonia concentration on the thermophilic digestion of cow manure. *Agricultural Wastes*, 14(1), 19-35. doi: 10.1016/S0141-4607(85)80014-7
- Zhang, R., Tao, J., & Dugba, P. (2000). Evaluation of two-stage anaerobic sequencing batch reactor systems for animal wastewater treatment. *Transactions of the ASAE*, 43(6), 1795-1801.
- Zhang, R., Yin, Y., Sung, S., & Dague, R. (1997). Anaerobic treatment of swine waste by the anaerobic sequencing batch reactor. *Transactions of the ASAE*, 40(3), 761-767.
- Ziemba, C., & Peccia, J. (2012). Fecal coliform population dynamics associated with the thermophilic stabilization of treated sewage sludge. *Journal of Environmental Monitoring*, 14(10), 2755-2761. doi: 10.1039/c2em30373f

APPENDICES

Appendix A Analytical Methods

A summary of the analytical methods used in this study are shown in Table A.1.

More detail on each procedure is given below.

Table A.1: Summary of analytical methods

Parameter	Method	MDL	Method range	Reference
pH and alkalinity	Standard method (2320 B)	N/A	N/A	APHA et al., 2012
CH₄ content	Standard method (6211 C)	N/A	N/A	
TS and VS	Standard method (2540G)	N/A	N/A	
TN	Standard methods (4500-NO ₃ ⁻ E and 4500-P E)	0.70 mg N/L	0.30 - 30.0 mg N/L	
TP	Standard method (4500-P J)	0.04 mg P/L	Up to 3.50 mg P/L	
TAN	Salicylate colorimetric method	0.70 mg NH ₄ ⁺ -N/L	Up to 15.5 mg NH ₄ ⁺ -N/L	Willis et al., 1996
Soluble COD	Standard method (5200B)	30.0 mg COD/L	Up to 15.0 g COD/L	APHA et al., 2012
VFA	Volatile acids esterification spectrophotometer method	14.0 mg COD/L	Up to 0.58 g COD /L	Montgomery et al., 1962
Readily biodegradable COD	OUR respirometry method	N/A	N/A	Young & Cowan 2004
MDL = Method detection limit				

A.1 pH and Alkalinity

Standard method 2320 B was used for measuring pH and alkalinity using Metrohm 827 (Riverview, FL) pH lab and 865 Dosimat Plus respectively. Titration was done using a 0.011 N H₂SO₄ solution to reach a pH end point of 4.5 for alkalinity determination. Eq 8.1 was used to calculate alkalinity.

Appendix A (Continued)

$$\text{Alkalinity } \left(\frac{\text{g CaCO}_3}{\text{L}} \right) = \frac{\text{Dilution} \times 50000 \times 0.011 \text{ (N)} \times \text{Volume of acid titrated (mL)}}{1000 \times \text{Volume of sample (mL)}}$$

(Eq 8.1)

A.2 Biogas Volume and Methane Content

During phase I of this study, biogas was collected in 10.0 L flexfoil gas bags from SKC Inc (Eighty Four, PA). The biogas volume in the bags was determined using water displacement by emptying the biogas into a tube containing water and measuring the volume of water displaced by the gas. Biogas was emptied twice a week. CH₄ content was measured by injecting 10 μL of biogas sample into a gas chromatograph (Gow Mac instrument CO. Bethlehem, PA) with using helium as a carrier gas. Injector temperature during analysis was maintained at 120°C while the detector and column temperatures were both at 80°C. The Current was maintained at 80mA.

During phase II of the study, biogas volume was monitored using Wet Tip gas meters (Wayne, PA). CH₄ content was determined using 3.0N NaOH based on the volumetric standard method (6211 C). A 10 μL volume of sample biogas was injected into a 100 mL glass serum bottle with a septum cap containing 100 mL 3.0 N NaOH. CO₂ was absorbed by the strong base and the liquid discharged from the bottle was captured on to a weighing pan and weighed. Figure 8.1 shows the set-up for the method. Using a calibration curve (Figure 8.2) produced from CH₄ standards CH₄ content in the biogas was estimated. CH₄ standards were prepared using 99% pure CH₄ from Air Liquide America Specialty Gases LLC (Plumsteadville, PA).

Appendix A (Continued)



Figure A.1: CH₄ content analysis set-up

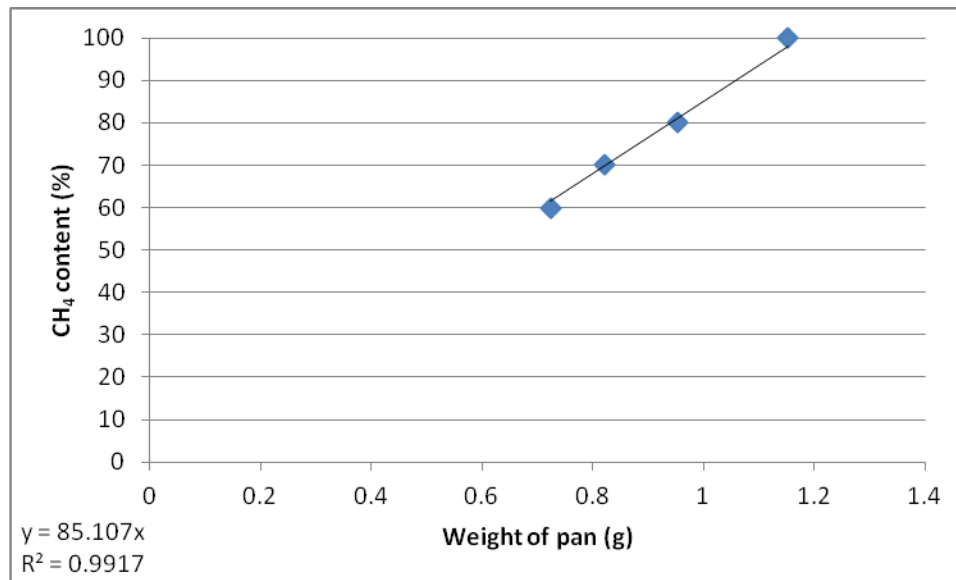

Figure A.2: CH₄ calibration curve using 3.0N NaOH

A.3 Total Phosphorus

TP analysis involved a persulfate digestion step at 120°C for 2 hours (Standard Method: 4500-P E) to oxidize all forms of P in the sample into orthophosphate. This was followed by reduction of orthophosphate to phosphomolybdic acid, to form molybdenum blue (Standard Method 4500-P J; APHA et al., 2012). The maximum concentration for

Appendix A (Continued)

this method was 3.5 mg P/L. The method detection limit was 0.04 mg P/L. The spectrophotometer wavelength was 880 nm. Stock solutions were prepared using adenosine triphosphate based on Standard Method: 4500-P E to produce the calibration curve below. No modifications were made to the Standard Methods used to measure TP.

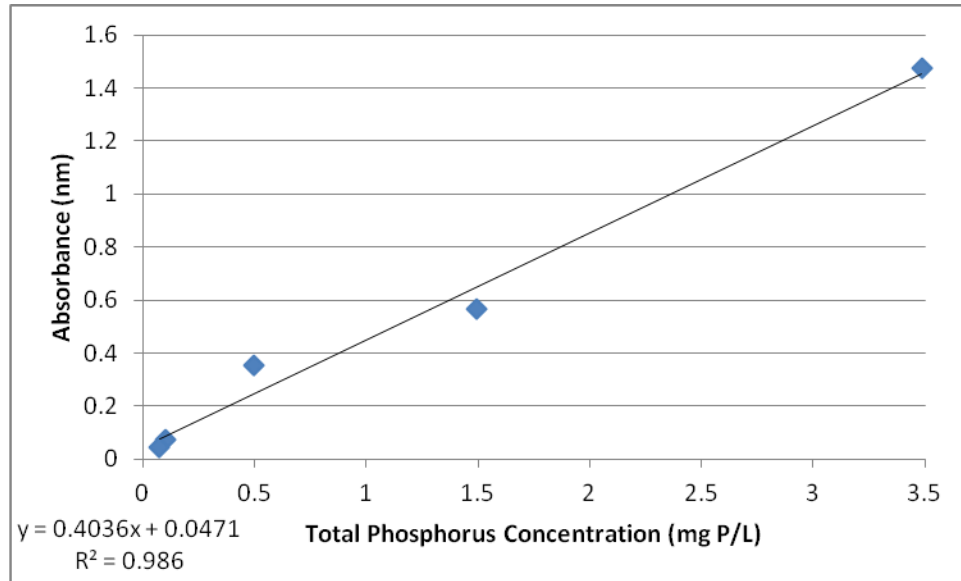

Figure A.3: TP calibration curve using stock solutions prepared using adenosine triphosphate and a spectrophotometer wavelength of 880 nm

A.4 Total Nitrogen

TN analysis involved the persulfate digestion used for TP analysis (Standard Method: 4500-P E) which converted all forms of N in the sample to $\text{NO}_3^- \text{N}$. This was followed by cadmium reduction (Standard Method: 4500- $\text{NO}_3^- \text{E}$) using Hach (Loveland, CO) NitraVer 5 nitrate reagent test pillows to reduce NO_3^- to NO_2^- . The analysis range was between 0.3 to 30 mg N/L, with a minimum detection limit of 0.7 mg N/L. The spectrophotometer wavelength used was 543 nm. Stock solutions were prepared using

Appendix A (Continued)

nicotinic acid *p*-toluenesulfonate based on Standard Method: 4500-P E to produce the calibration curve below.

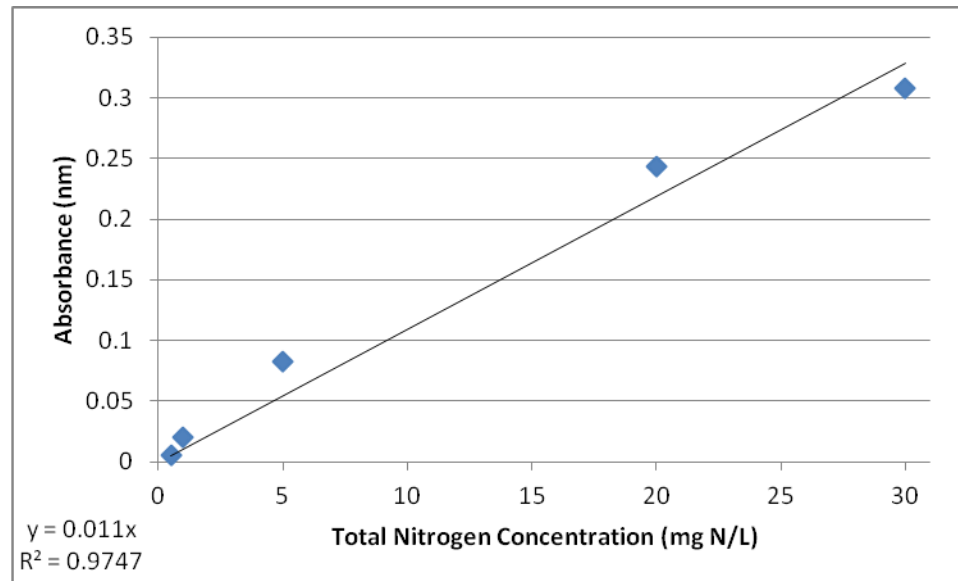

Figure A.4: TN calibration curve using stock solutions prepared using nicotinic acid *p*-toluenesulfonate and a spectrophotometer wavelength of 543 nm

A.5 TAN

The NH_4^+ -N testing method used was adapted from Willis et al. (1996) with modification for color reagent storage time. The stock solution was prepared using ammonium chloride according to Standard Method 4500-NH₃ D to achieve concentrations up to 15.5 mg NH_4^+ -N /L. The minimum detection limit for this method was 0.7 mg NH_4^+ -N /L. Spectrophotometer wavelength was 685 nm.

A.5.1 Reagents

1. *Color Reagent*: Mixed 32.0 g of anhydrous sodium salicylate with 40.0 g trisodium phosphate, $\text{Na}_3\text{PO}_4 \cdot 12 \text{H}_2\text{O}$ (TSP) and 0.5 g sodium nitrosylpentacyanoferrate (III) (sodium nitroprusside) into a 1.0L volumetric flask

Appendix A (Continued)

and diluted to 1.0 L with DI water. This reagent can be stored at 4°C for up to 1 month.

2. *Hypochlorite Reagent*: Fifty mL of commercial bleach containing 5.0-5.3% sodium hypochlorite was diluted into 1.0 L of DI water. This reagent was stored in an amber bottle at room temperature for up to two months.

A.5.2 Method

1. Appropriate centrate dilution was made to yield concentration between 1.0-14 mg NH_4^+ -N/L using DI water.
2. Sample volume (0.2 mL) was pipetted into a dry test tube.
3. 4.0 mL of the *color reagent* was added to the test tube.
4. The mixture was vortexed using the Scientific Industries Vortex Genie 2 (Bohemia, NY) to achieve a homogenous mixture.
5. 1.0 mL of the *hypochlorite reagent* was then added and vortexed.
6. The solution was allowed to react for 12 min.
7. Absorbance was measured using a Hach DR/2400 spectrophotometer (Loveland, CO).
8. This solution is stable for 18 hours. The calibration curve is illustrated below.

Appendix A (Continued)

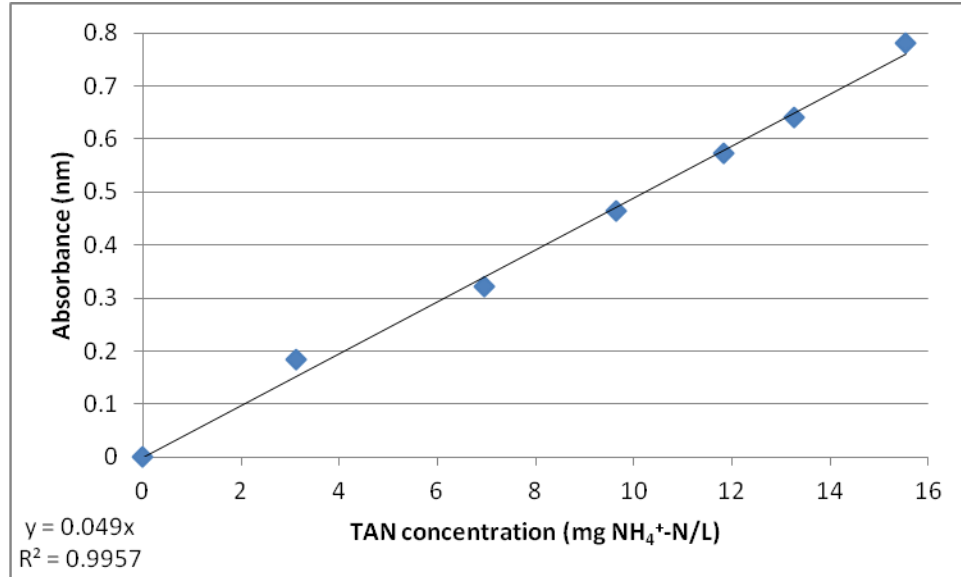

Figure A.5: TAN calibration curve using stock solutions prepared using ammonium chloride and a spectrophotometer wavelength of 685 nm

A.6 COD

The closed reflux colorimetric Standard Method 5200B (APHA et al., 2012) was used for COD using Orbeco TR125 (Sarasota, FL) heating block and Hach DR/2400 spectrophotometer. The method detection limit for COD was 30.0 mg COD/L. Orbeco high range COD reagent tubes (Reagent number: TT20712) were used for COD analysis. A stock solution was prepared using potassium hydrogen phthalate according to Standard Method 5200B, to achieve maximum concentrations up to 15.0 g COD/L (test tube maximum limit). Spectrophotometer wavelength for COD was 600 nm. The calibration curve is illustrated below.

Appendix A (Continued)

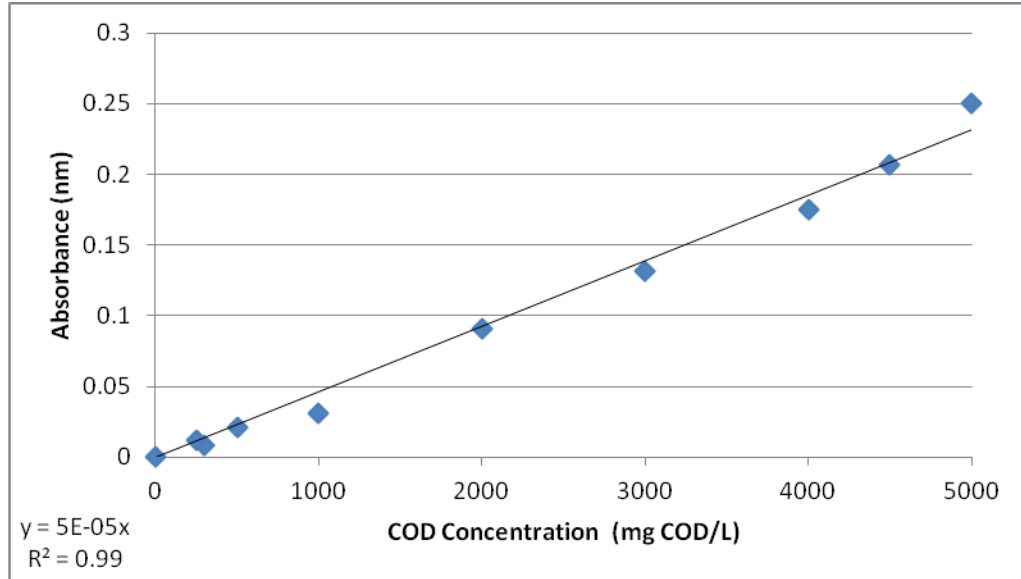

Figure A.6: COD calibration curve using stock solutions prepared using potassium hydrogen phthalate and a spectrophotometer wavelength of 600 nm

A.7 VFA

The VFA testing method was adapted from Montgomery et al. (1962), with modification to wavelength. This method works by converting carboxylic acid groups in the sample to esters using ethylene glycol and sulphuric acid. The esters are then converted to hydroxamic acids by reacting with hydroxylamine hydrochloride. Addition of acidic ferric chloride reacts with the acids to form ferric complexes that are measured (Siedlecka et al., 2008). The stock solution was prepared using acetic acid according to Standard Method 5560C to achieve acetate concentrations up to 1.20 g acetate/L. The minimum detection limit for this method was 28.0 mg acetate/L. Spectrophotometer wavelength was 500 nm.

Appendix A (Continued)

A.7.1 Reagents

1. *Diluted H₂SO₄ acid reagent:* Mixed 50.0 mL H₂SO₄ acid with 50 mL DI water in a 100.0 mL volumetric flask. The reagent was stored at 4°C for up to 3 months.
2. *Acidic ethylene glycol reagent:* In a 50.0 mL flask, 30.0 mL of ethylene glycol was mixed with 4.0 mL of the *diluted H₂SO₄ acid reagent*. A fresh batch of reagent was made for each analysis.
3. *4.5N NaOH base:* In a 50.0 mL volumetric flask, 9.0 g of NaOH was dissolved with DI water. A fresh batch of base was made for each analysis.
4. *Combined hydroxylamine hydrochloride reagent:* Ten percent of hydroxylamine hydrochloride reagent was prepared. Five mL of this reagent was then mixed with 20.0 mL of *4.5N NaOH*. The combined reagent was made fresh right before use. The *10% hydroxylamine hydrochloride reagent* was stored at 4°C for up to 3 months.
5. *Acidic Ferric Chloride Reagent:* In a 1.0 L volumetric flask, 20.0 g of ferric chloride hexahydrate was dissolved in 500.0 mL of DI water, 20.0 mL of H₂SO₄ acid was added and solution was and diluted to 1.0 L. The reagent was stored at 4°C for up to 3 months.

A.7.2 Method

1. Appropriate centrate dilution was made to bring the sample in the range of 0.03 – 0.12 g acetate/L using DI water.
2. A sample volume of 0.5 mL was pipetted into a dry test tube.

Appendix A (Continued)

3. 1.7 mL of *acidic ethylene glycol reagent* was added to the test tube and shaken thoroughly.
4. Test tubes were then heated in a boiling water bath for 3 minutes using Isotemp heating plate (Dubuque, IO). It was ensured that the test tubes did not come into contact with the heating plate.
5. The test tubes were then immediately cooled in cold water bath for 3 minutes.
6. 2.5 mL of *combined hydroxylamine hydrochloride reagent* was added to the test tubes and mixture was vortexed.
7. The test tubes were set aside for 1 minute and contents were emptied in a 25 mL volumetric flask.
8. 10 mL of *acidic ferric chloride reagent* was pipette into the volumetric flask.
9. DI water was added to make up to the 25 mL mark on the flask. Contents of the flasks were vortexed to ensure homogeneity. Absorbance was measured at 500 nm.

Appendix A (Continued)

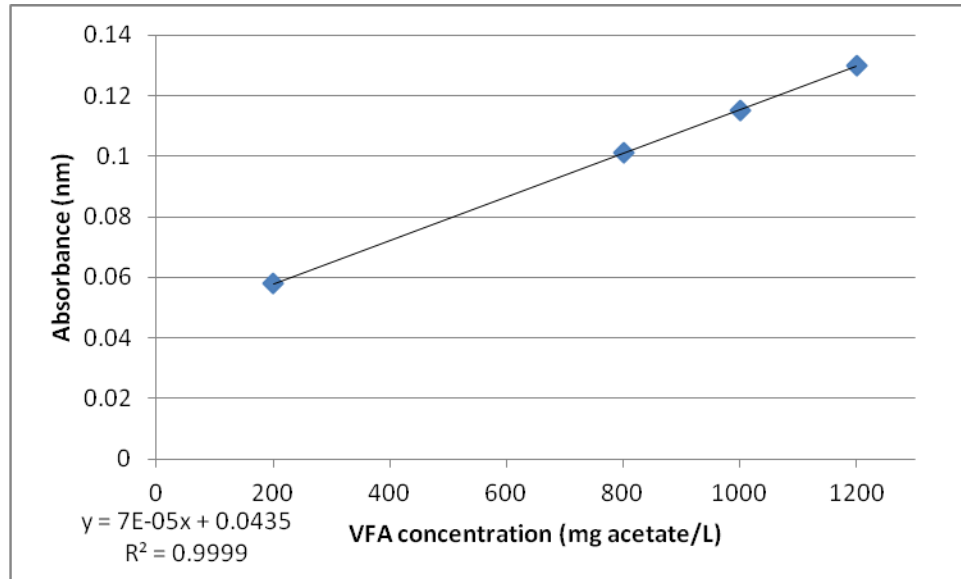
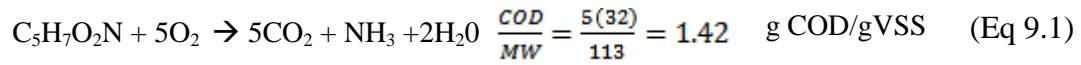

Figure A.7: VFA calibration curve using stock solutions prepared using acetic acid and a spectrophotometer wavelength of 500 nm

Appendix B: Mass Balances

B.1 COD Mass Balance

Before calculating the residual biodegradable COD (S_{bp}) concentration using Monod kinetics, half saturation coefficient (K_s) and maximum specific growth rate (μ_{max}) values were calculated. Equations in the data analysis sections were used to calculate total influent particulate COD (Eq 4.1), unbiodegradable soluble COD (Eq 4.4), biodegradable particulate (Eq 4.3) and hydrolysis rate (Eq 4.10). Total effluent particulate COD was calculated using Eq 9.1 and 9.2. To calculate μ_{max} and K_s values, a S_{bp} was required; however, this value was unknown. Therefore a first order kinetics equation was used to calculate S_{bp}^* (Eq 9.3). This S_{bp}^* value was used to plot the linearization curves that were needed to determine μ_{max} and K_s values.



$$X_{tem} = O_2 \text{ equivalents} \times \text{effluent VS concentration (g/L)} \quad \text{g COD/L} \quad (\text{Eq 9.2})$$

$$S_{bp}^* = \frac{X_{tim} [f_{PS'up} + E(1 - f_{PS'up})] - X_{tem}}{[E - 1]} \quad \text{g COD/L} \quad (\text{Eq 9.3})$$

$$\text{where } E = \frac{Y_{AD}}{1 + b_{AD}SRT(1 - Y_{AD})}$$

Monod kinetic constants were determined using two linearization methods, (i) Lineweaver-Burke (Figure 9.1) and (ii) Eadie-Hofstee (Figure 9.2). These linearization methods gave different half saturation coefficient (K_s) and maximum specific growth rate (μ_{max}) for Monod hydrolysis kinetics values (Sötemann et al., 2005b). K_s and μ_{max} values from Eadie-Hofstee linearization were used to calculate the COD balance because it gave the best fit.

Appendix B (Continued)

Table B.1: First order kinetic calculations

Parameter		Unit	14 day	21 day	28 day
Total influent particulate COD	X_{ti}	g COD/L	29.2	43.7	61.7
Total effluent particulate COD	X_{te}	g COD/L	19.4	25.5	33.7
Influent VFA	S_{bai}	g COD/L	2.13	3.2	3.86
Unbiodegradable soluble COD	S_I	g COD/L	7.30	10.9	15.4
Biodegradable particulate COD	X_s	g COD/L	19.8	29.6	42.4
First order kinetics residue biodegradable COD	S_{bp}^*	g COD/L	9.43	9.80	11.2
Hydrolysis rate	r_h	g COD/L-d	0.75	0.97	1.15
Acidogen biomass	Z_{AD}	g COD/L	2.21	4.11	6.30

Note: X_{ti} , X_{te} and S_{bai} were experimental data while all other values were calculated

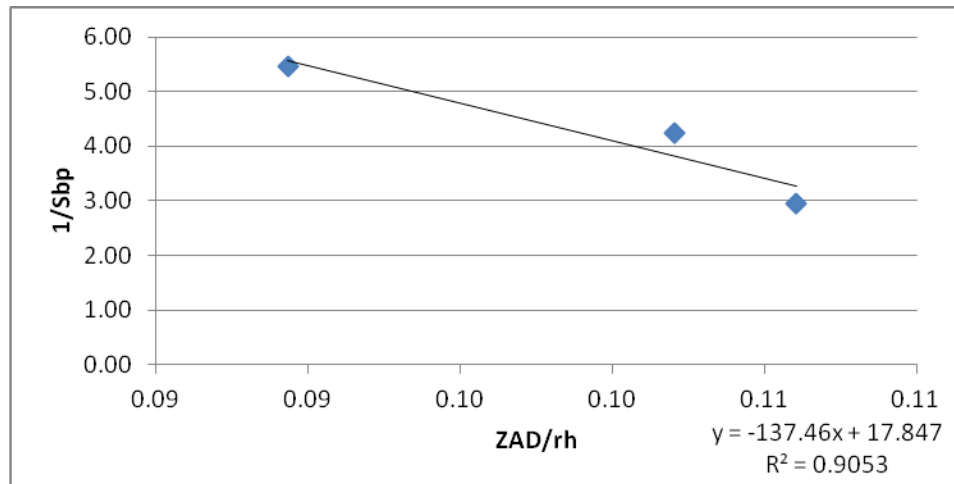

Figure B.1: Lineweaver-Burke linearization and regression method for the three reactors

Appendix B (Continued)

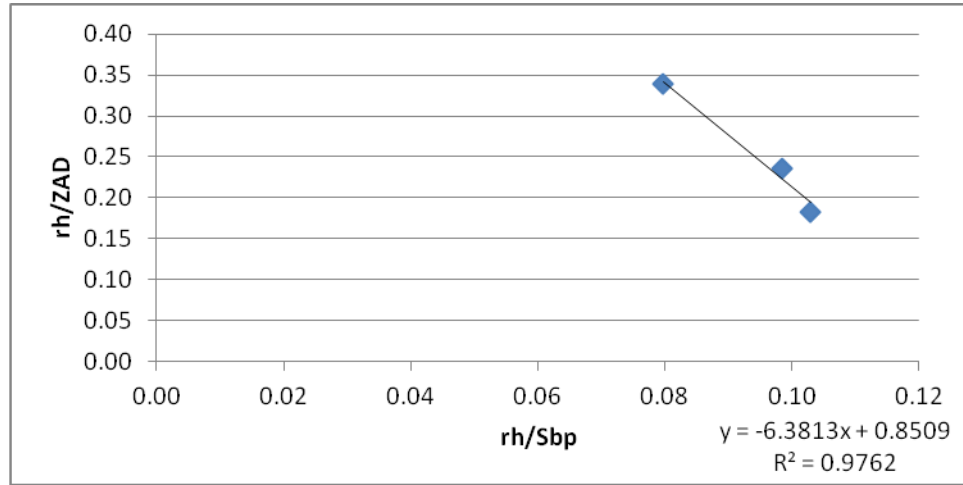

Figure B.2: Eadie-Hofstee linearization and regression method for the three reactors

Table B.2: Linearization methods and calculated kinetic constants for Monod kinetics

Linearization		μ_{max}	K_S	R^2
		g COD/g VS-d	g COD/L	
Lineweaver-Burke	$1/\mu_{max} = y$ intercept $K_S/\mu_{max} = \text{slope}$	0.06	-7.7	0.91
Eadie-Hofstee	$\mu_{max} = y$ intercept $K_S = -\text{slope}$	0.85	6.38	0.98

Using the kinetic constants derived for Monod kinetics shown on Table 9.2, r_h and S_{bp} were re-calculated using Eq 4.13 and 4.14 respectively. Z_{AD} was re-calculated with the new S_{bp} value using Eq 4.12.

R2 with 21 day SRT will be used as a design example using Monod hydrolysis rate equations and kinetic constants.

Measured total influent COD (X_{tim}) = 43.7 g COD/L

Influent VFA (S_{bai}) = 3.20 g COD/L

Unbiodegradable fraction of the swine waste ($f_{PS,up}$) = 0.25

Appendix B (Continued)

Influent biodegradable particulate COD (X_I) = $(1-0.25)43.7 - 3.20 = 29.6$ g COD/L

Influent unbiodegradable Soluble influent COD (C_I) = $0.25 \times 43.7 = 10.9$ g COD/L

Residual biodegradable COD (S_{bp}) = 0.03 g COD/L (Eq 4.14)

Biodegradable COD removed ($S_{bpr} = S_{bpi} - S_{bp}$) = $29.6 - 0.03 = 29.5$ g COD/L

Acidogen biomass concentration (Z_{AD}) = 6.14 g COD/L (Eq 4.12)

Unbiodegradable soluble effluent COD ($S_I = C_I$) = 10.9 g COD/L

Total effluent COD ($S_T = S_I + S_{bp} + Z_{AD}$) = $10.9 + 0.03 + 6.14 = 17.1$ g COD/L

CH₄ production concentration (S_m) = 23.4 g COD/L (Eq 4.17)

Calculated total influent COD (X_{tic}) = $S_m + S_I + S_{bp} + Z_{AD} = 40.5$ g COD/L (Eq 4.18)

COD balance $100 (X_{tic} / X_{im}) = 92.7\%$

B.2 Nitrogen Mass Balance

R2 with 21 day SRT will be used as a design example using input output kinetics.

$C_{TI} = 0.078 (48.1) + 1.09 = 4.84$ g N/L (Eq 4.27)

$C_{TE} = 0.12 (18.1) + 1.54 = 3.71$ g N/L

Total nitrogen balance = $(100 \times 3.71)/4.84 = 76.7\%$ (Eq 4.28)

B.3 Phosphorus Mass Balance

R2 with 21 day SRT will be used as a design example

$P_{TI} = 0.02 (57.3) + (130/1000) = 1.28$ g P/L

$P_{TE} = 0.024 (35.5) + (64.4/1000) = 0.88$ g N/L

Total phosphorus balance = $(100 \times 0.88)/1.28 = 68.8\%$

Appendix C: Phase I Graphs

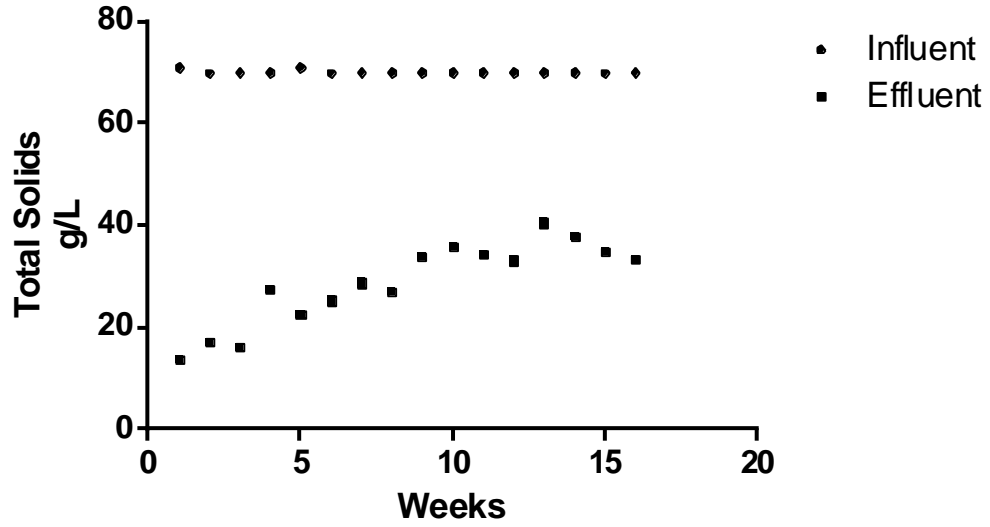

Figure C.1: Total Solids influent and effluent concentrations for 16 weeks of Phase I

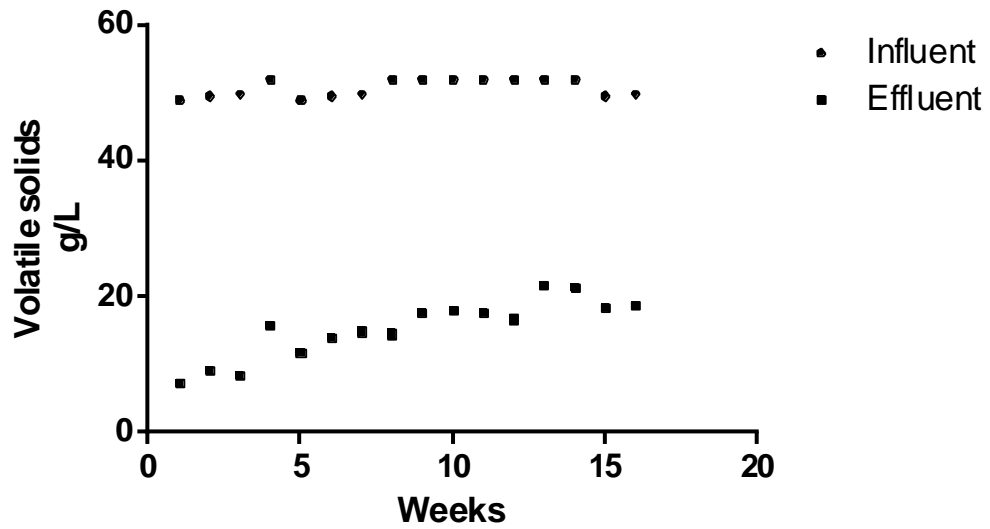

Figure C.2 Volatile Solids influent and effluent concentrations for 16 weeks of Phase I

Appendix C (Continued)

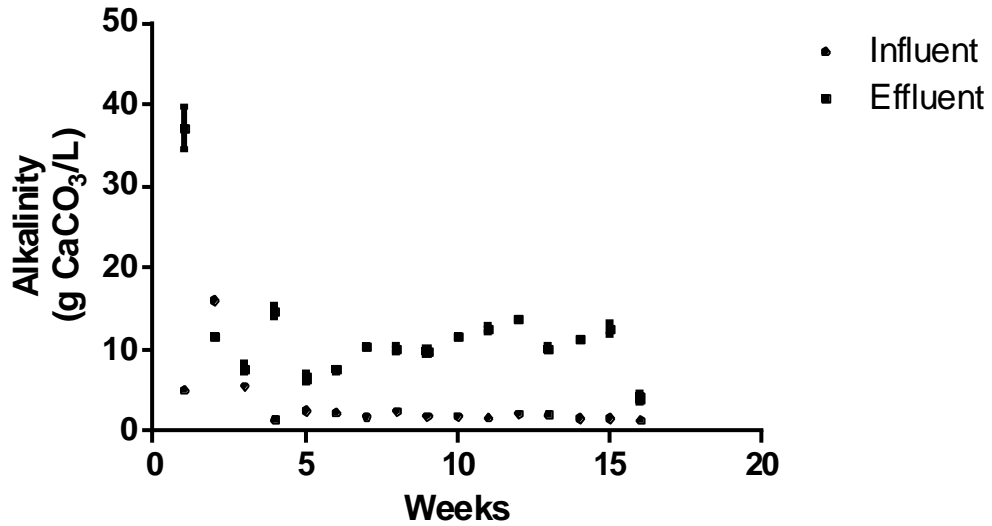

Figure C.3: Alkalinity influent and effluent concentrations for 16 weeks of Phase I

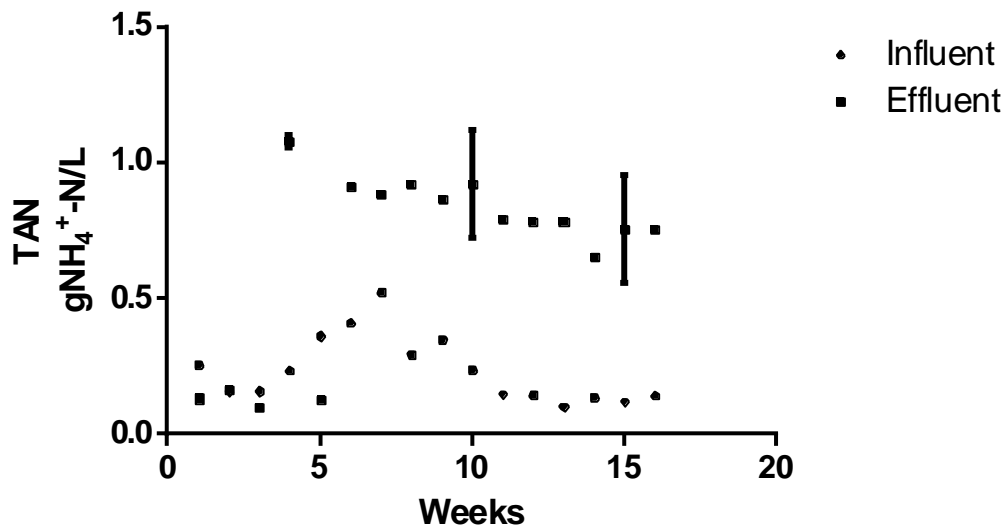

Figure C.4: TAN influent and effluent concentrations for 16 weeks of Phase I

Appendix C (Continued)

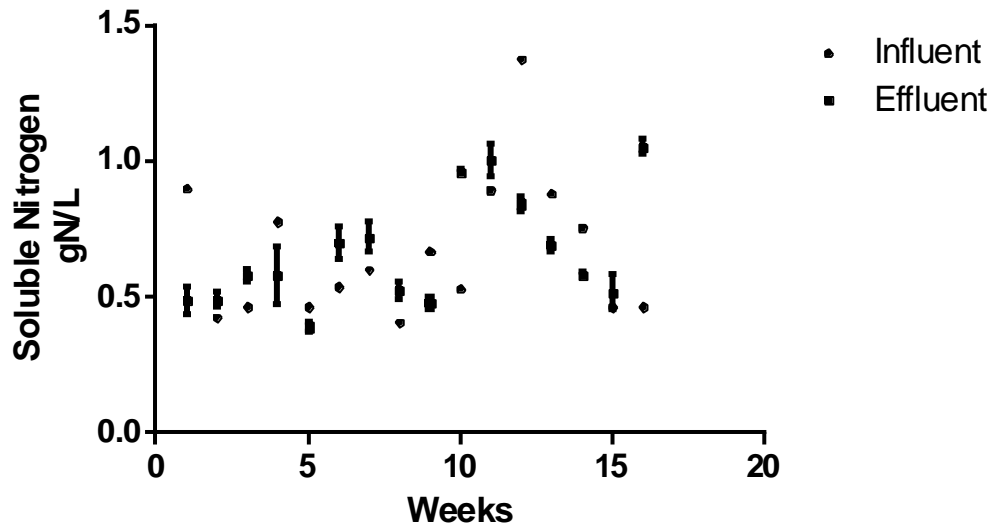

Figure C.5: Soluble Nitrogen influent and effluent concentrations for 16 weeks of Phase I

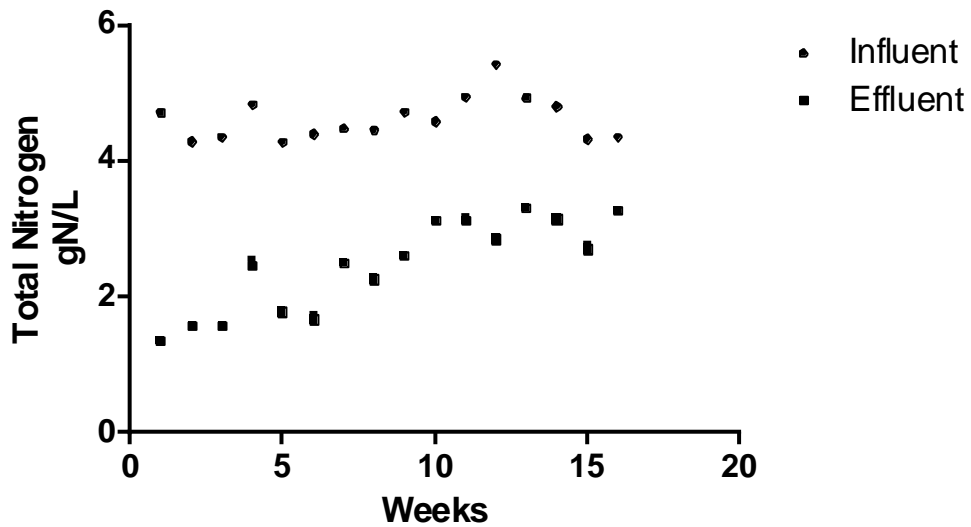

Figure C.6: Total Nitrogen influent and effluent concentrations for 16 weeks of Phase I

Appendix C (Continued)

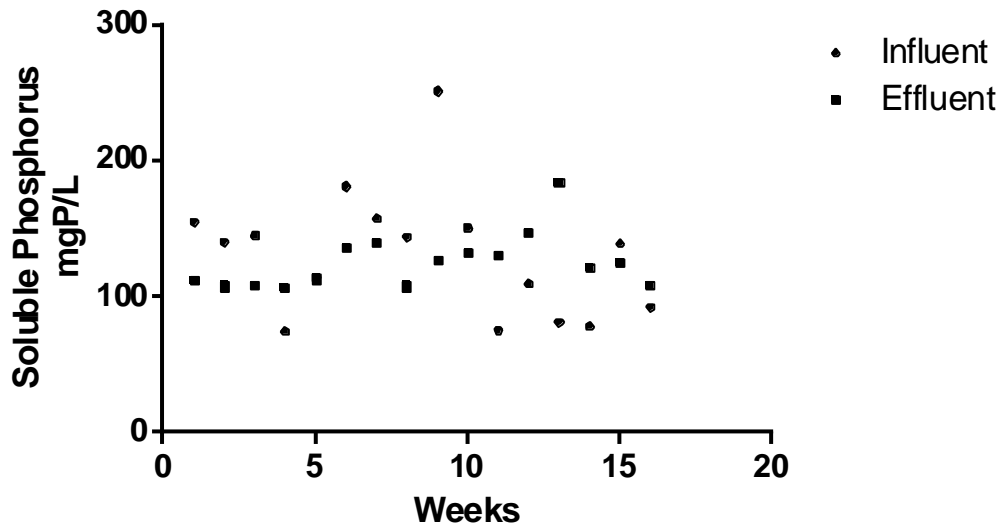

Figure C.7: Soluble Phosphorus influent and effluent concentrations for 16 weeks of Phase I

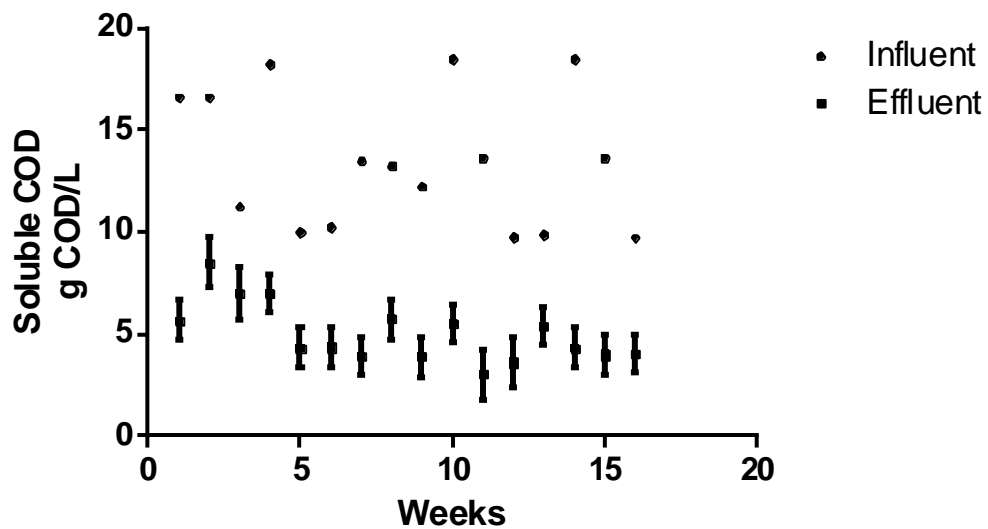

Figure C.8: Soluble COD influent and effluent concentrations for 16 weeks of Phase I

Appendix C (Continued)

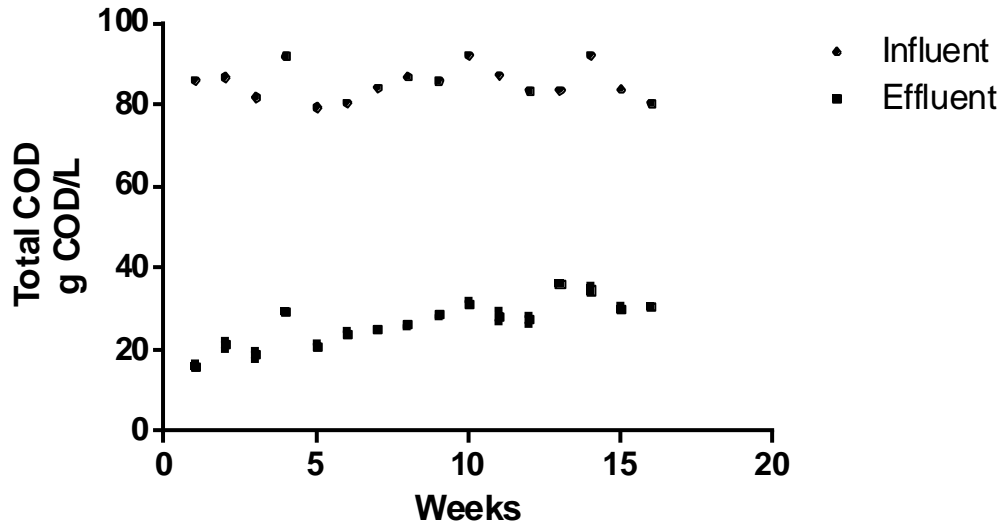

Figure C.9: Total COD influent and effluent concentrations for 16 weeks of Phase I

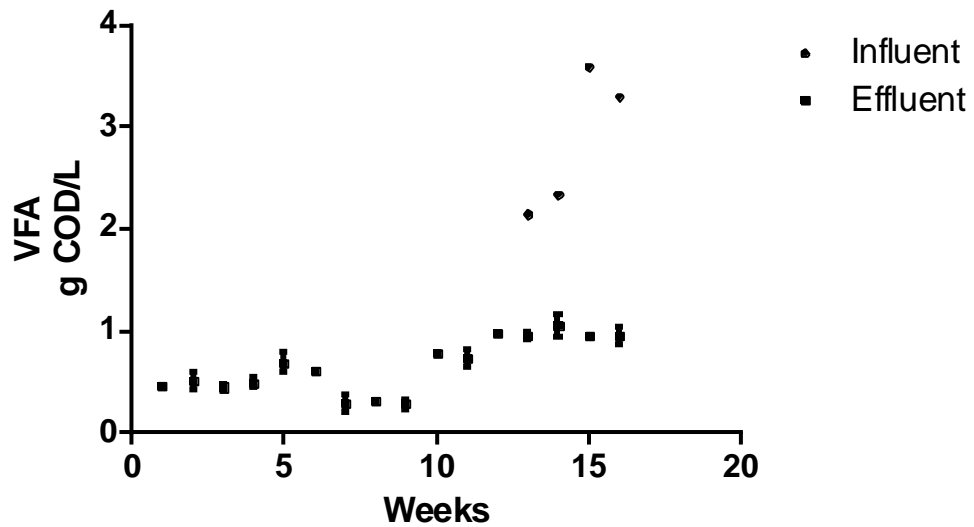

Figure C.10: Total COD influent and effluent concentrations for 16 weeks of Phase I

Appendix D: List of Acronyms

ANAMMOX	Anaerobic Ammonium Oxidation	US	United States
BAP	Biomass Associated Products	SBR	Sequencing Batch Reactor
BNR	Biological Nutrient Removal	SHARON	Single reactor system for High activity Ammonium Removal Over Nitrite
BOD	Biological Oxygen Demand	S _I	Soluble Inert COD
CAFO	Concentrated Animal Feeding Operations	SMP	Soluble Microbial Products
CHP	Combined Heat and Power	S _P	Soluble Residual Products
COD	Chemical Oxygen Demand	SRB	Sulfate Reducing Bacteria
DI	Deionized water	S _S	Readily Biodegradable COD
DNR	Dissimilatory Nitrate Reduction	SS	Suspended Solids
DO	Dissolved Oxygen	S _T	Effluent COD
F/M	Food to Microorganisms Ratio	TAN	Total Ammonia Nitrogen
FA	Free Ammonia	TKN	Total Kjeldahl Nitrogen
EU	European Union	TN	Total Nitrogen
GHG	Green House Gas	TOC	Total Organic Carbon
GWP	Global Warming Potential	TP	Total Phosphorus
HRT	Hydraulic Retention Time	TS	Total Solids
MAUREEN	Main-stream AUtotrophic Recycle Enabling Enhanced N-removal	VFA	Volatile Fatty Acids
MLE	Modified Ludzack-Ettinger	VS	Volatile Solids
NOB	Nitrite Oxidizing Bacteria		
NOD	Nitrogenous Oxygen Demand		
NUR	Nitrate Uptake Rate		
OU	Oxygen Uptake		
OUR	Oxygen Uptake Rate		

Appendix E: List of Equation Nomenclature

b_{AD}	Acidogen Endogenous Respiration rate	S_E	Total Effluent organic nitrogen
C_I	Total Unbiodegradable COD	S_F	Fermentable COD
C_S	Total Biodegradable COD	S_H	Rapidly Hydrolysable COD
C_T	Total Influent COD	S_I	Unbiodegradable Soluble COD
C_{TEL}	Total Effluent Nitrogen in liquids	S_m	Methane Production Concentration
C_{TES}	Total Effluent Nitrogen in solids	S_{PP}	Struvite Precipitation Potential
C_{TIL}	Total Influent Nitrogen in liquids	S_{upi}	Influent Unbiodegradable COD
C_{TIS}	Total Influent Nitrogen in solids	S_S	Biodegradable Soluble COD
F_g	Gaseous Free Ammonia	S_T	Total Effluent COD
F_{NE}	Fraction of Effluent Nitrogen in solids	Q_m	Methane Production Gas Volume
F_{NI}	Fraction of Influent Nitrogen in solids	X_E	Total Effluent Inorganic Nitrogen
$f_{PS'up}$	Unbiodegradable fraction of the swine waste	X_H	Active Biomass
P_{TE}	Effluent Phosphorus	X_I	Unbiodegradable particulate COD
P_{TI}	Influent Phosphorus	X_S	Biodegradable particulate COD
S_A	Fermentation Products COD	X_{SH}	Slowly Hydrolysable COD
S_{bai}	Influent VFA	X_{tim}	Measured Total Influent Particulate COD
S_{bp}	Residual Biodegradable COD	X_{tic}	Calculated Total Influent Particulate COD
S_{bpr}	Biodegradable COD Removed	Y_{AD}	Acidogen Yield Coefficient
S_{bpi}	Influent Biodegradable COD	Z_{AD}	Acidogen biomass concentration